

fiberglass BOX™

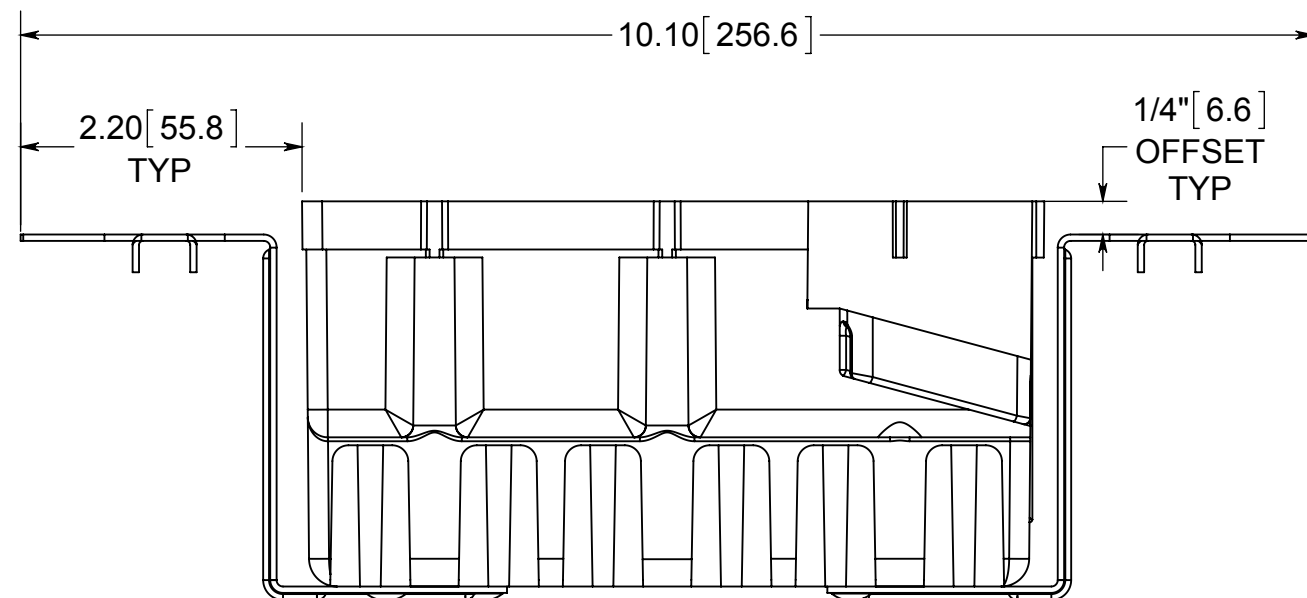

- NOTES:
- 1.) BOX MATERIAL: FIBERGLASS REINFORCED POLYESTER, BRACKET MATERIAL: GALVANIZED STEEL, SPEED KLAMP MATERIAL: PVC
 - 2.) UL LISTED WITH 2 HOUR FIRE RATING FOR WALL AND CEILING
 - 3.) "Z" HANGER BRACKET USED TO ATTACH BOX TO FACE OF WOOD OR STEEL STUDS. SECURE WITH APPROVED FASTENERS PER THE APPLICATION REQUIREMENTS. **ALLIED MOULDED PRODUCTS** 4/6 SPEED KLAMPS FACTORY, DRYAN, OHIO

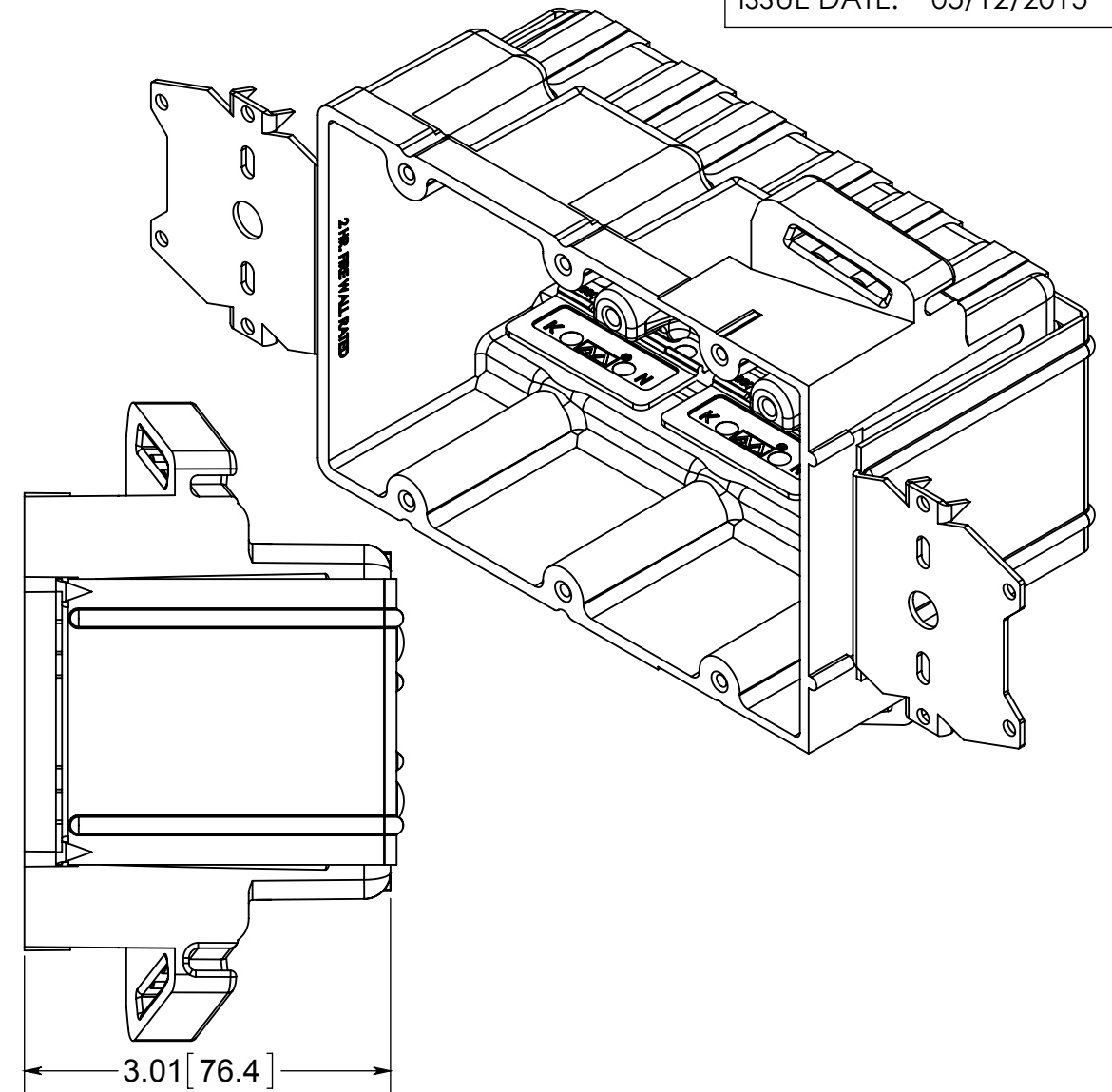
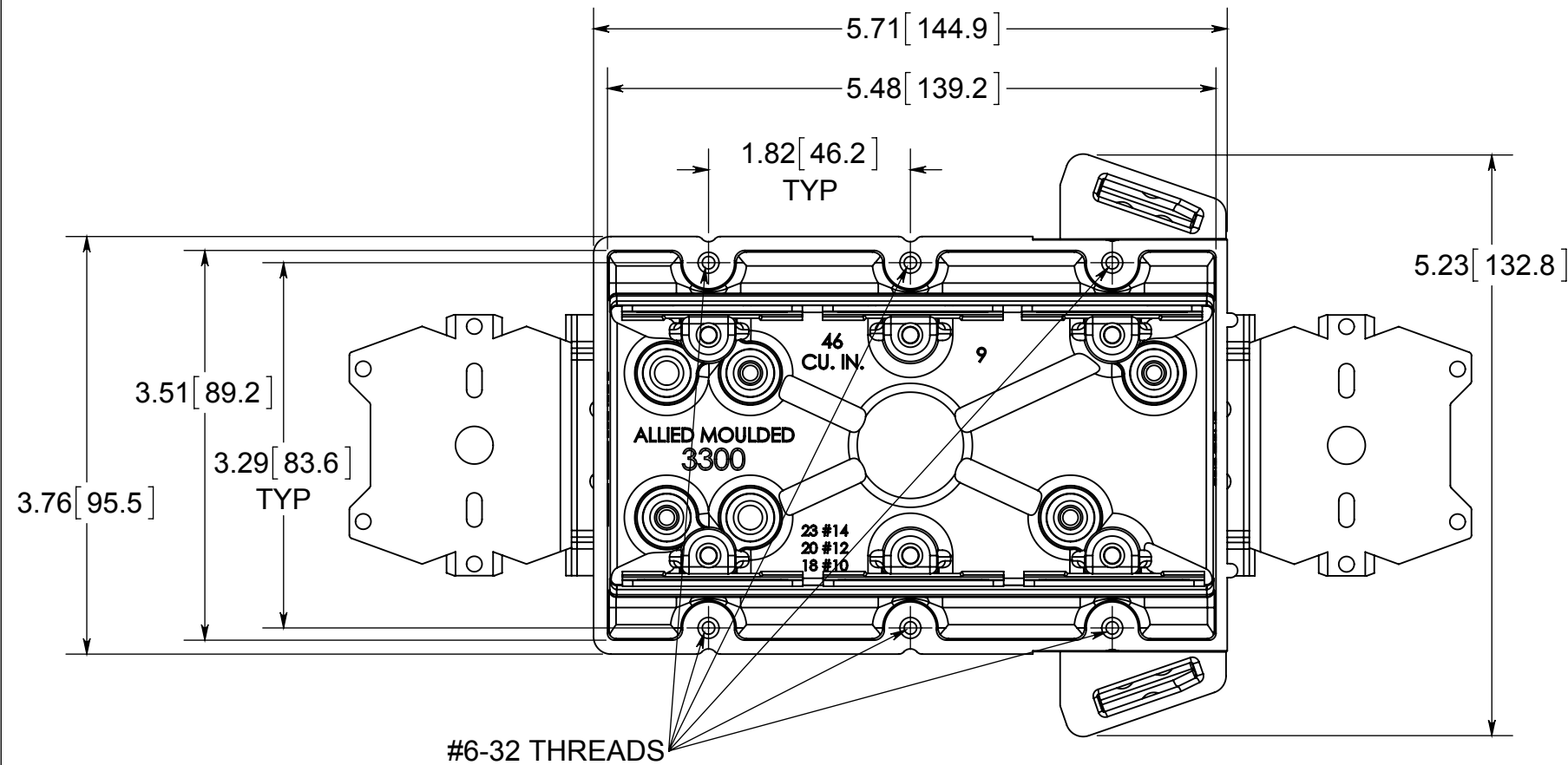

The Original Fiber Glass Outlet Box

PRODUCT SERIES

THREE GANG 46.0 CU. IN.

Part No.

3300-2Z2K

CONFIDENTIAL

THIS MATERIAL IS OWNED BY THE ALLIED MOULDED PRODUCTS COMPANY, IS DISCLOSED IN CONFIDENCE, AND IS NOT TO BE REPRODUCED OR DISTRIBUTED WITHOUT PRIOR WRITTEN PERMISSION FROM ALLIED MOULDED PRODUCTS.