

fiberglass BOX™

ISSUE DATE: 12/18/2025

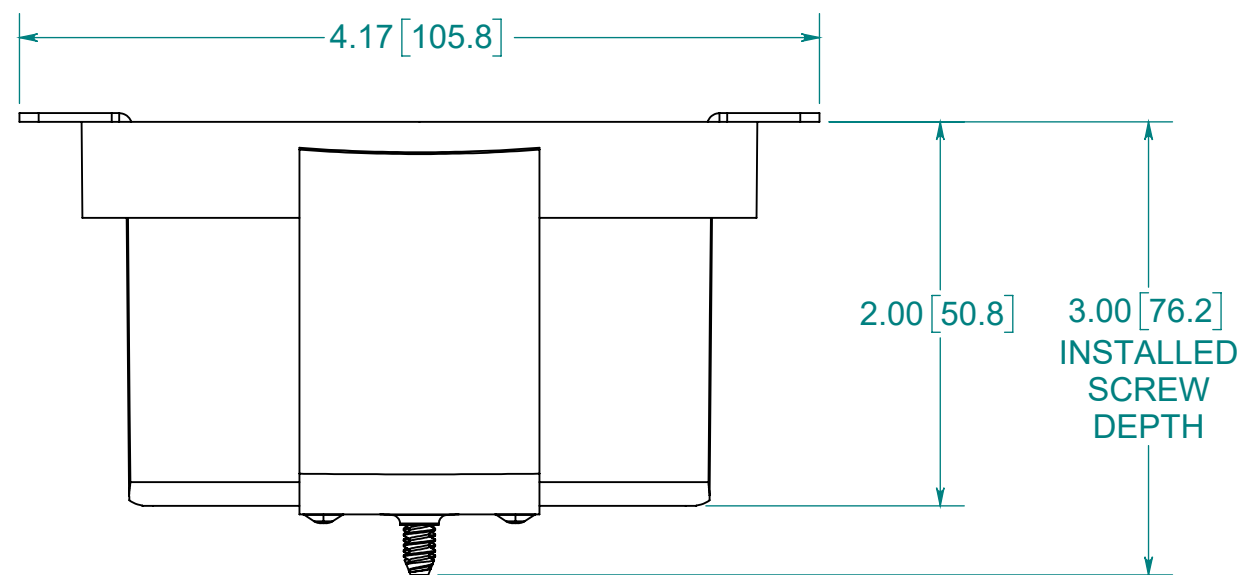
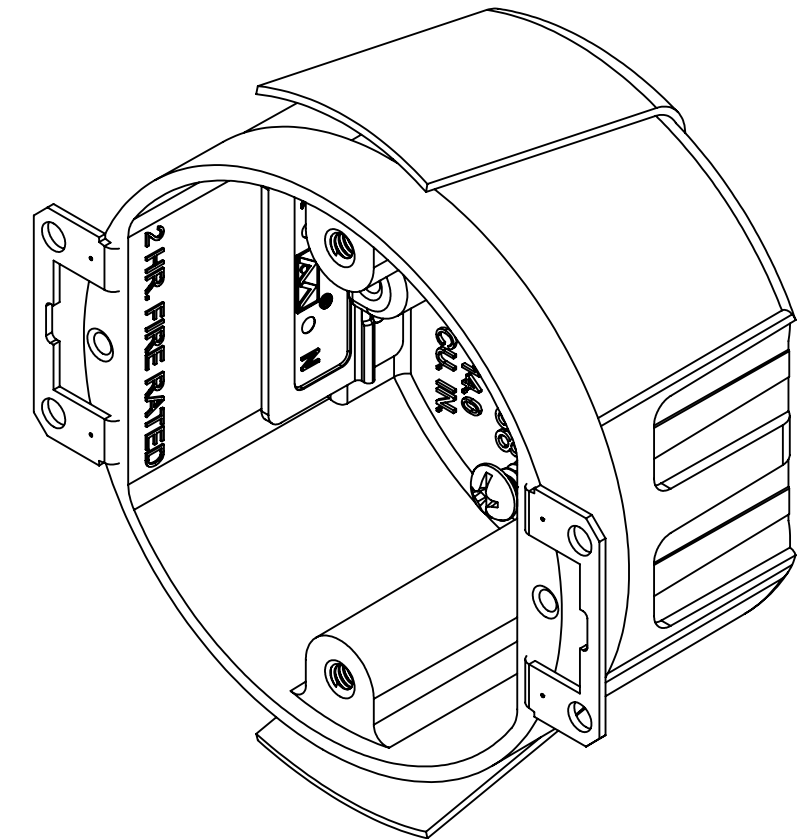
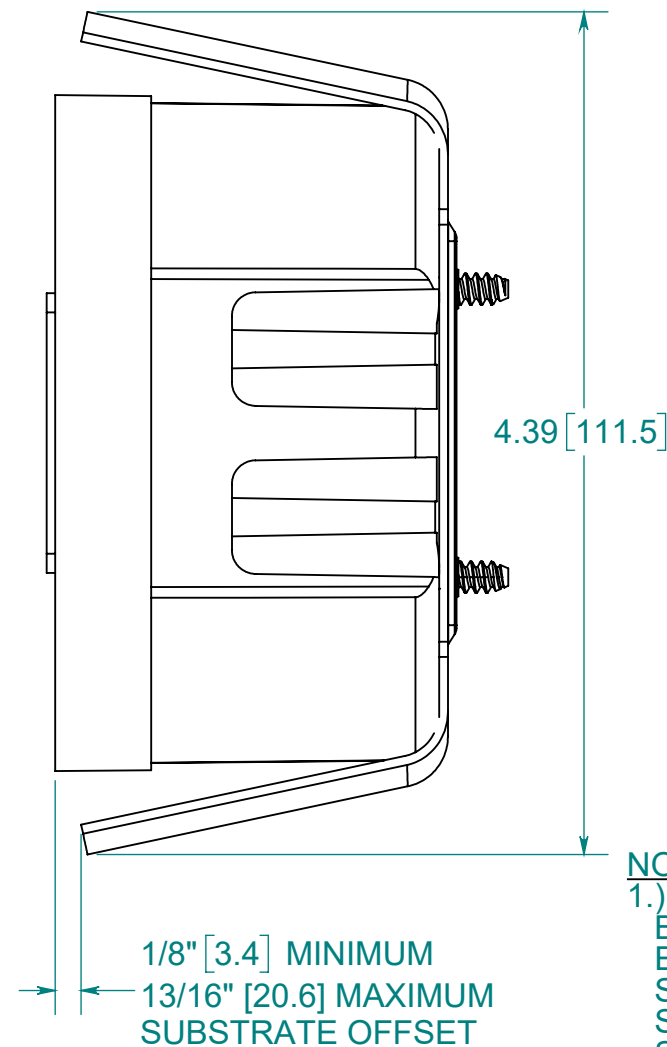
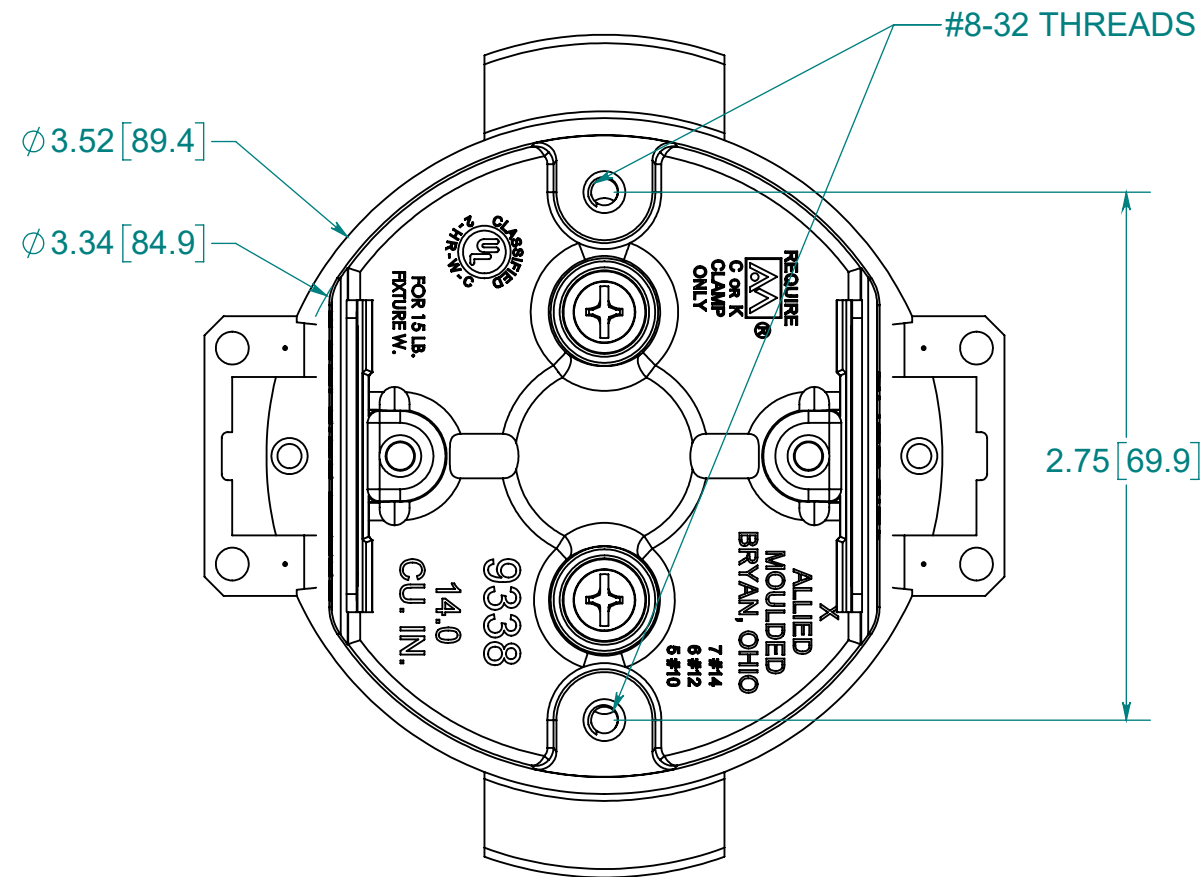

NOTES:

- 1.) MATERIALS:
 BOX: FIBERGLASS REINFORCED POLYESTER
 EARS: GALVANIZED STEEL
 SNAP BRACKET: GALVANIZED STEEL
 SNAP BRACKET SCREW: ZINC PLATED STEEL
 SPEED KLAMP: PVC
- 2.) UL LISTED WITH 2 HOUR FIRE RATING FOR WALL AND CEILING
- 3.) 2 SPEED KLAMPS FACTORY INSTALLED
- 4.) DIMENSIONS ARE FOR REFERENCE ONLY AND SUBJECT TO CHANGE WITHOUT NOTICE



® **ALLIED MOULDED PRODUCTS**
BRYAN, OHIO

The Original Fiber Glass Outlet Box

PRODUCT SERIES

3-1/2" DIA. OLD WORK 14 CU. IN. W/ EARS,
 SNAP BRACKET & SPEED KLAMPS

Part No.

9338-ESK

CONFIDENTIAL

THIS MATERIAL IS OWNED BY THE ALLIED MOULDED PRODUCTS COMPANY, IS DISCLOSED IN CONFIDENCE, AND IS NOT TO BE REPRODUCED OR DISTRIBUTED WITHOUT PRIOR WRITTEN PERMISSION FROM ALLIED MOULDED PRODUCTS.