

316 STAINLESS STEEL DRAW LATCH (PADLOCK PROVISIONED) AND KEEPER PLATE TYP (3x)

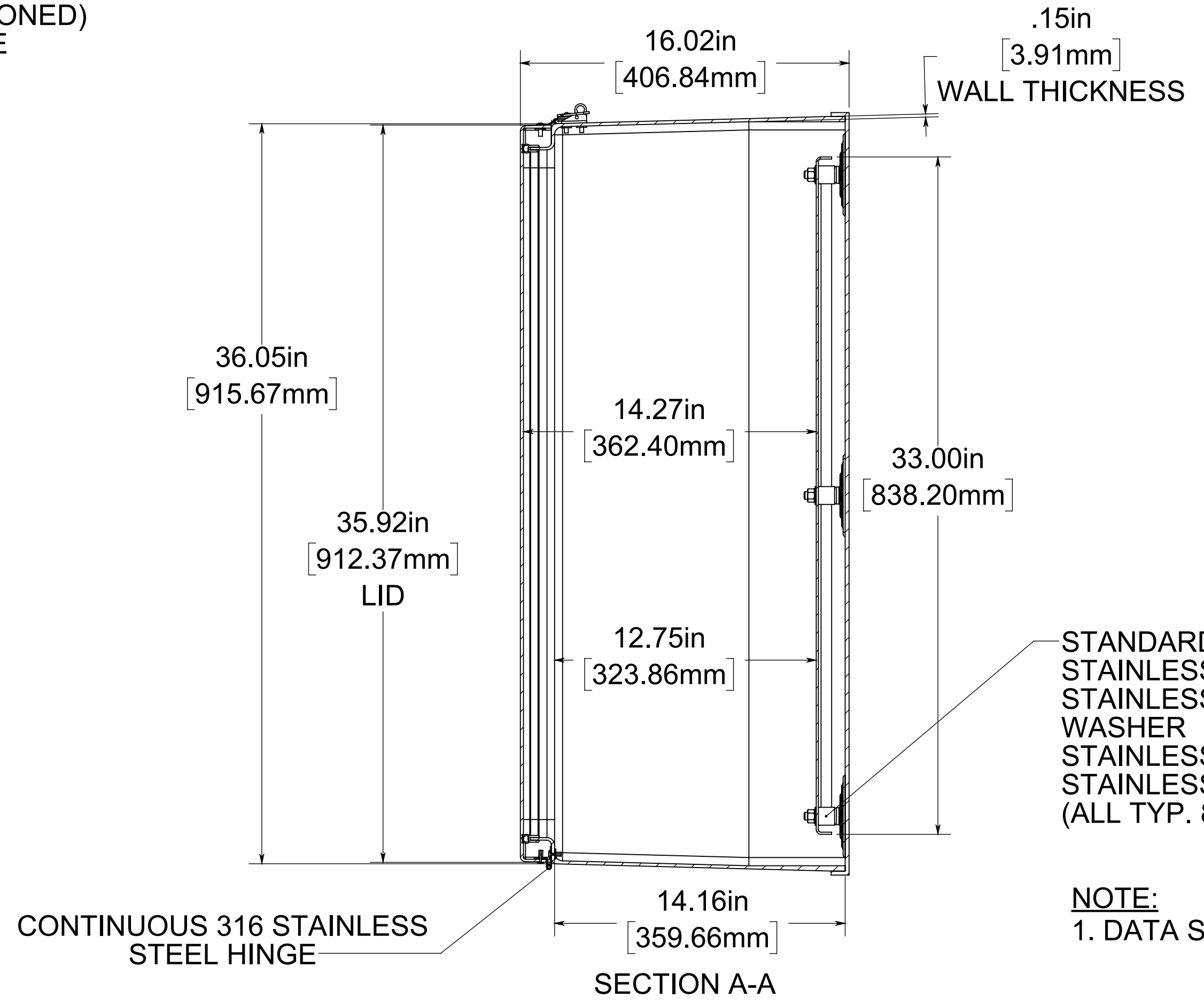

STANDARD PVC SPACER
 STAINLESS STEEL 3/8-16x2 THREADED ROD
 STAINLESS STEEL 3/8 INT. TEETH LOCKING WASHER
 STAINLESS STEEL FLAT WASHER
 STAINLESS STEEL 3/8-16 HEX HEAD NUT (ALL TYP. 8x)

NOTE:
 1. DATA SUBJECT TO CHANGE

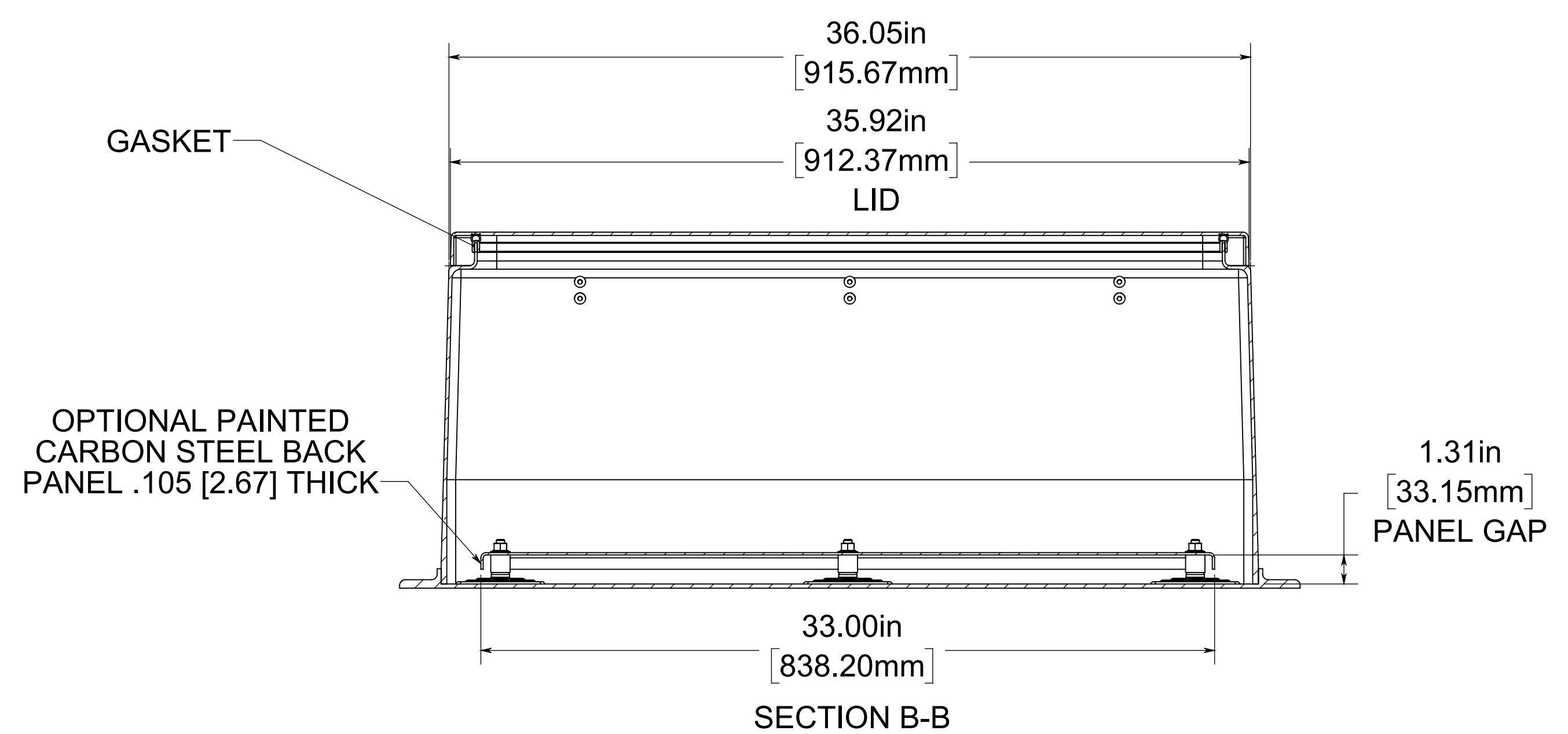

GASKET

OPTIONAL PAINTED CARBON STEEL BACK PANEL .105 [2.67] THICK

SECTION B-B

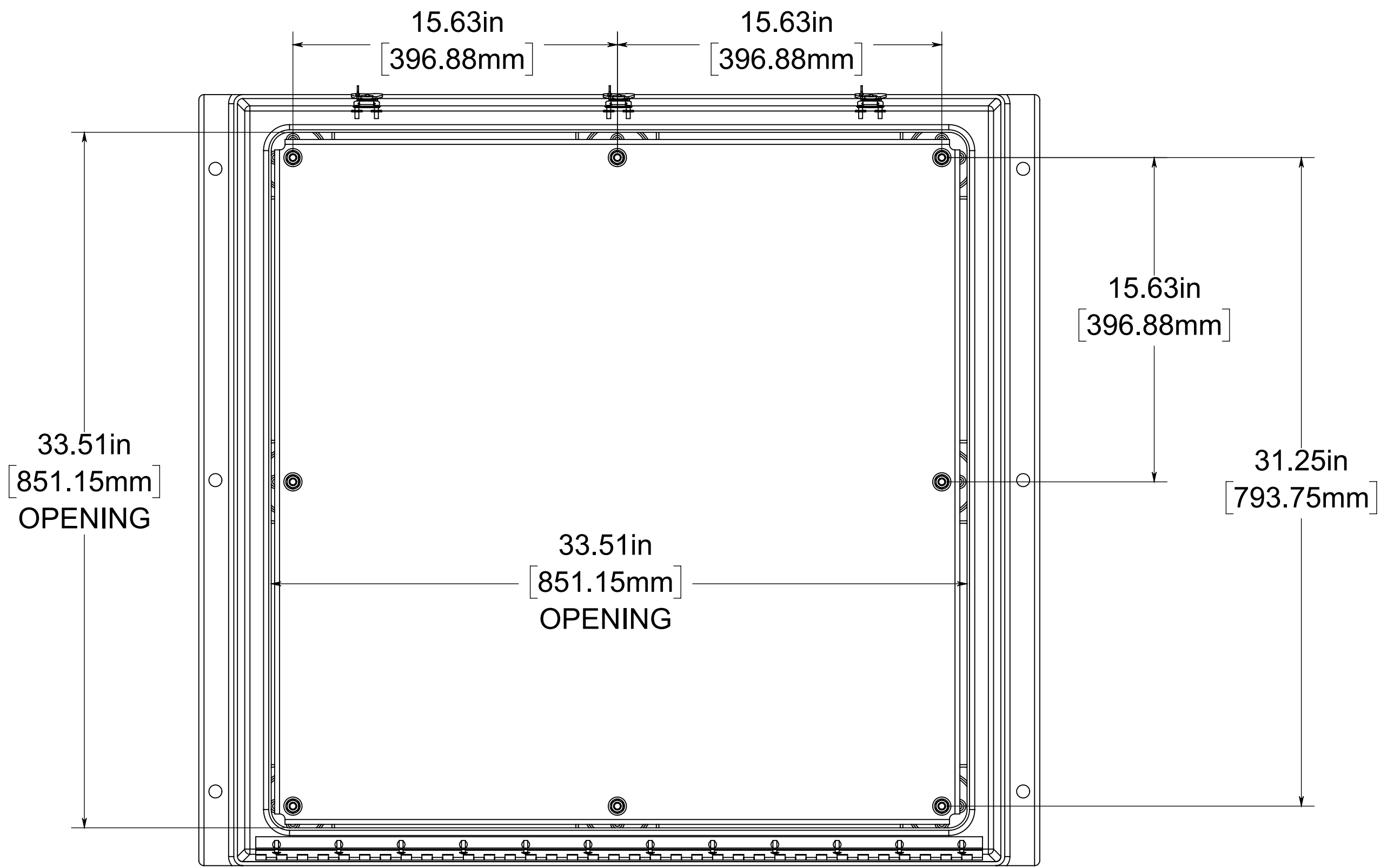

TOP VIEW WITH COVER AND GASKET REMOVED

MATERIAL:

BOX- GEL-COAT, FIBERGLASS, POLYESTER RESIN
 COVER- GEL-COAT, FIBERGLASS, POLYESTER RESIN
 EDM GASKET SEAL

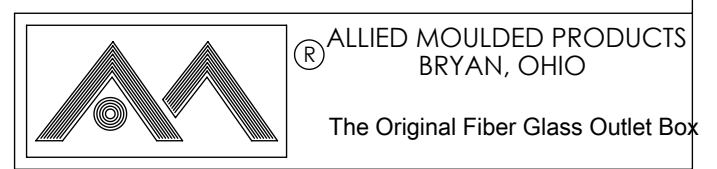

Empire
 Part No. AM363616L

CONFIDENTIAL
 THIS MATERIAL IS OWNED BY THE ALLIED MOULDED PRODUCTS COMPANY, IS DISCLOSED IN CONFIDENCE, AND IS NOT TO BE REPRODUCED OR DISTRIBUTED WITHOUT PRIOR WRITTEN PERMISSION FROM ALLIED MOULDED PRODUCTS.