



**ALLIED
MOULDED
PRODUCTS, Inc.**

Inspection Window Installation
Installation Instructions for Inspection Window
AMHMI138CX

Instructions for Installing Inspection Window

NOTE: Philips Screw Driver or similar tool is required to install cover.

1. Punch out the template center.
2. Place template on flat smooth surface and mark hole locations and panel opening as shown.
3. Remove template and drill or cut holes 5/16" (0.312 DIA.) and opening accordingly.
4. Mount Inspection Window with supplied mounting hardware. Hardware applicable to mounting surface thickness of .059" - .250". Hardware torque specification 12 – 15 in-lbs.
5. Hardware included:
 - 70-10325, 10-32 X 1/2" Pan Head Machine Screw; Quantity 10
 - 70-EMRWASHER, Stainless Steel Washer; Quantity 10

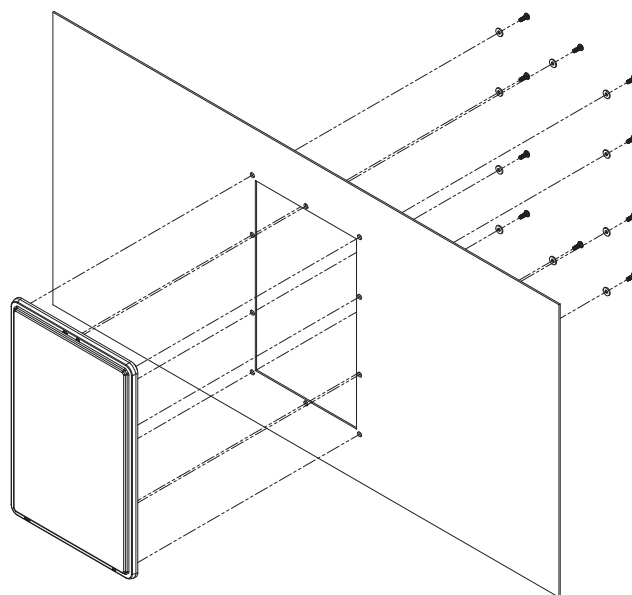

Allied Moulded Products, Inc.
222 North Union Street • Bryan, OH 43506
Phone: 1-800-722-2679 • Fax: 1-800-237-7269
www.alliedmoulded.com