



## Aluminum Hinged Front Panel Installation Instructions

HFP66  
HFP86  
HFP108  
HFP120  
HFP122  
HFP142  
HFP164  
HFP186  
HFP206  
HFP2020  
HFP2420  
HFP2424  
HFP3024



**Allied Moulded Products, Inc.**  
222 North Union Street  
Bryan, OH 43506  
Phone: 1-800-722-2679 • Fax: 1-800-237-7269  
[www.alliedmoulded.com](http://www.alliedmoulded.com)



HINGE FRONT PANEL ASSEMBLY PROCEDURE

INSTRUCTIONS FOR MOUNTING  
HINGE(S) TO BOX WITH T-NUTS (OLDER VERSIONS)

- STEP #1 INSTALL THE HINGE (1), MAKING SURE THE PANEL LEAF SIDE OF HINGE IS UP AND THE BOX LEAF SIDE GOES OVER THE T-NUT.
- STEP #2 INSTALL THE #6-32 X 3/16 SEMS PAN HEAD SCREWS (15) INTO THE T-NUTS AND TIGHTEN.

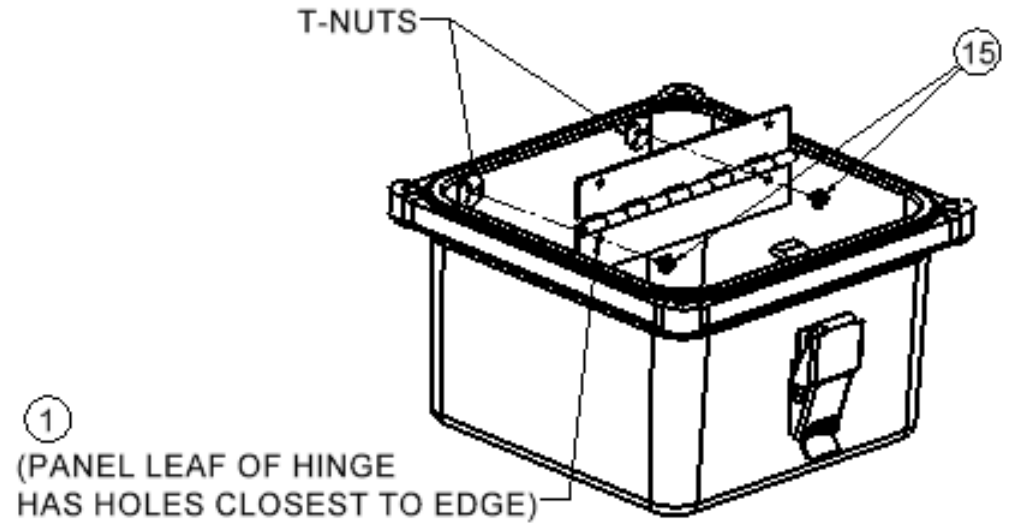

INSTRUCTIONS FOR MOUNTING  
HINGE(S) TO BOX WITHOUT T-NUTS

- STEP #1 INSTALL THE HINGE (1), MAKING SURE THE PANEL LEAF SIDE OF HINGE IS UP AND THE BOX LEAF SIDE GOES OVER THE BOX MOUNT HOLES.
- STEP #2 INSTALL THE #6 LOCK WASHERS (9) AND #6-20 X 5/16 PAN HEAD SCREWS (17) INTO THE BOX AND TIGHTEN.

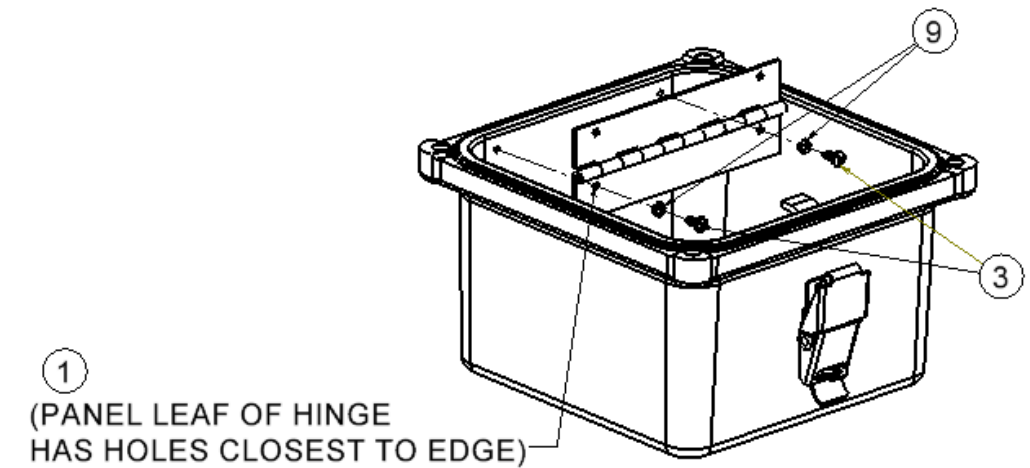

INSTRUCTIONS FOR MOUNTING  
THE PANEL STOP(S) TO THE BOX

- STEP #1 REMOVE THE EXISTING SCREW FROM THE EXISTING LATCH ASSEMBLY.
- STEP #2 REPLACE THE EXISTING #6-32 X 3/8 PAN HEAD SCREWS WITH #6-32 X 7/16 PAN HEAD SCREWS WITH O-RINGS (16).
- STEP #3 PLACE THE PANEL STOP (2) ON THE #6-32 X 7/16 PAN HEAD SCREWS (16) AT THE PROPER HEIGHT FOR THE PANEL ASSEMBLY. [SEE CHART (A)].  
NOTE: THERE ARE 3 POSSIBLE POSITIONS.
- STEP #4 REINSTALL THE DUAL NUT WITH DIMPLES AWAY FROM THE PANEL STOP AND TIGHTEN THE SCREWS (16) AND EXISTING LATCH TO THE BOX ASSEMBLY.

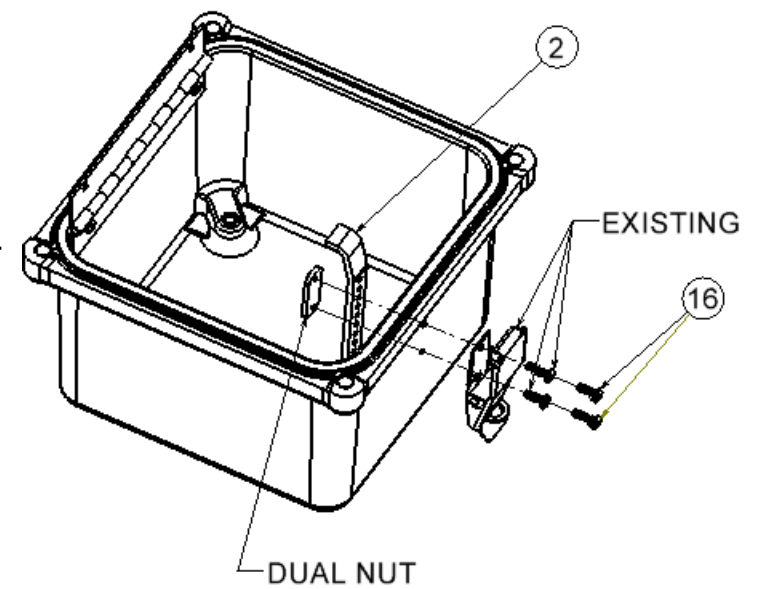

HINGE FRONT PANEL ASSEMBLY PROCEDURE

INSTRUCTIONS FOR MOUNTING  
SPRING LATCH TO PANEL

- STEP #1 MOUNT SPRING LATCH (5) TO PANEL (4) USING TWO POP RIVETS (6) AS SHOWN.  
**NOTE**  
FLANGE OF RIVET ON THE TOP OF THE PANEL

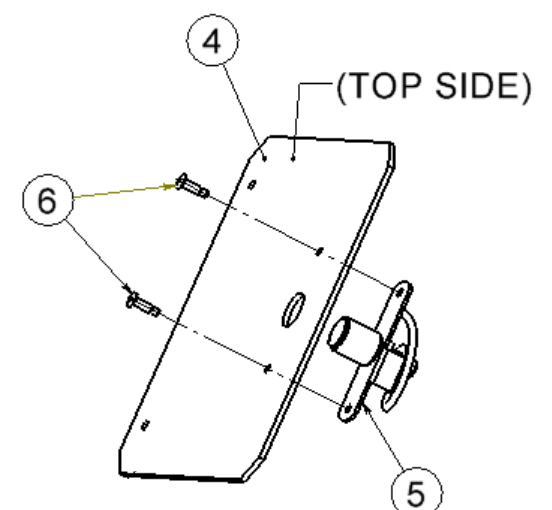



**INSTRUCTIONS FOR MOUNTING  
THE PANEL ON THE HINGE(S)  
(PANEL FLUSH TO TOP OF BOX)**

- STEP #1**      INSTALL #6-32 X 3/8 SLOTTED PAN HEAD SCREWS (7) AND #6 FLAT WASHERS (8) THROUGH THE MOUNT HOLES IN THE HINGE (1).
- STEP #2**      PLACE THE PANEL ASSEMBLY ON THE #6-32 X 3/8 SLOTTED PAN HEAD SCREWS (7).
- STEP #3**      ATTACH THE #6 LOCK WASHERS (9) AND ACORN CAP NUTS (10) TO THE #6-32 X 3/8 SLOTTED PAN HEAD SCREWS (7) AND TIGHTEN.

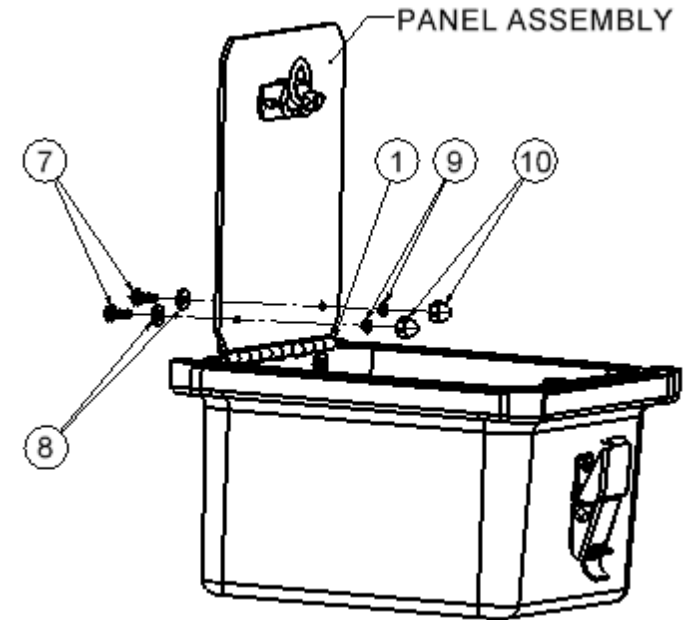

**ASSEMBLY FOR PANEL MOUNTED  
ONE HALF INCH ABOVE BOX**

- STEP #1**      INSTALL #6 FLAT WASHERS (8) ONTO #6-32 X 3/4 SCREWS (11).
- STEP #2**      INSERT THE #6-32 X 3/4 SCREWS (11) AND #6 FLAT WASHERS (8) THROUGH THE MOUNTING HOLES IN THE SWING PANEL ASSEMBLY.
- STEP #3**      PLACE LONG SPACERS (12) OVER THE #6-32 X 3/4 SCREWS (11) AND INSERT THE SCREWS THROUGH THE MOUNTING HOLES IN THE HINGE(S) (1).
- STEP #4**      ATTACH THE #6 LOCK WASHERS (9) AND ACORN CAP NUTS (10) ON TO THE #6-32 X 3/4 SCREWS (11) AND TIGHTEN.
- STEP #5**      INSTALL AND ADJUST PANEL STOP(S) PER PREVIOUS INSTRUCTIONS.

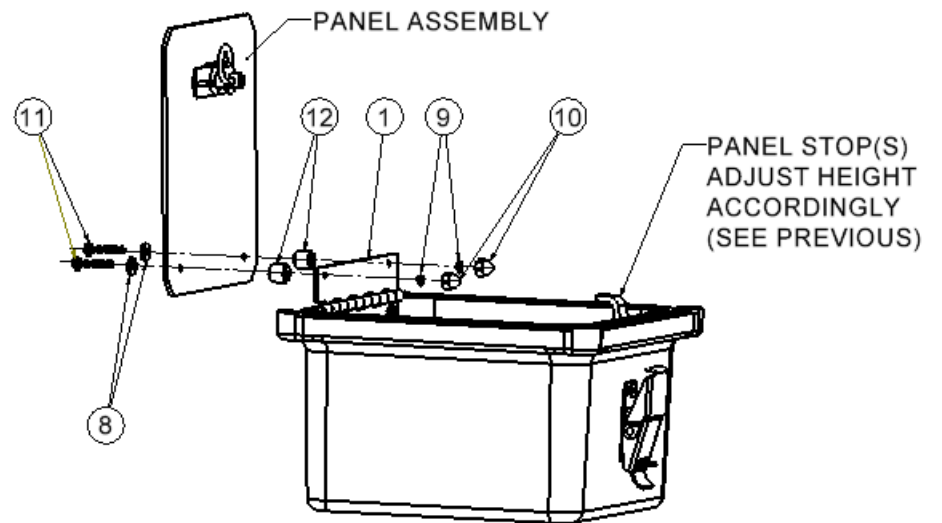

**ASSEMBLY FOR PANEL MOUNTED  
ONE HALF INCH BELOW BOX**

- STEP #1**      INSTALL #6 FLAT WASHERS (8) ONTO #6-32 X 7/8 SCREWS (13).
- STEP #2**      INSERT THE SCREWS AND FLAT WASHERS THROUGH THE MOUNTING HOLES IN THE HINGE(S) (1).
- STEP #3**      PLACE LONG SPACERS (12) AND SHORT SPACERS (14) OVER THE #6-32 X 7/8 SCREWS (13) AND INSERT THE SCREWS THROUGH THE MOUNTING HOLES IN THE SWING PANEL ASSEMBLY.
- STEP #4**      ATTACH THE #6 LOCK WASHERS (9) AND ACORN CAP NUTS (10) ON TO THE #6-32 X 7/8 SCREWS (13) AND TIGHTEN.
- STEP #5**      INSTALL AND ADJUST PANEL STOP(S) PER PREVIOUS INSTRUCTIONS.

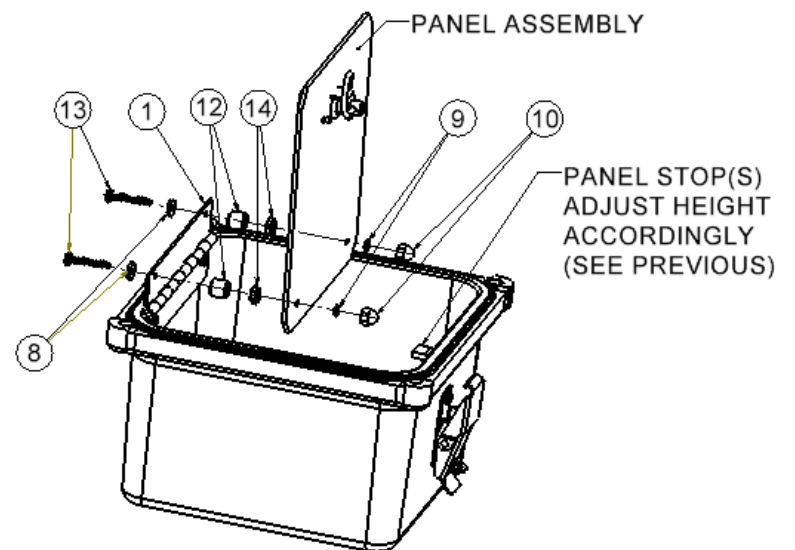
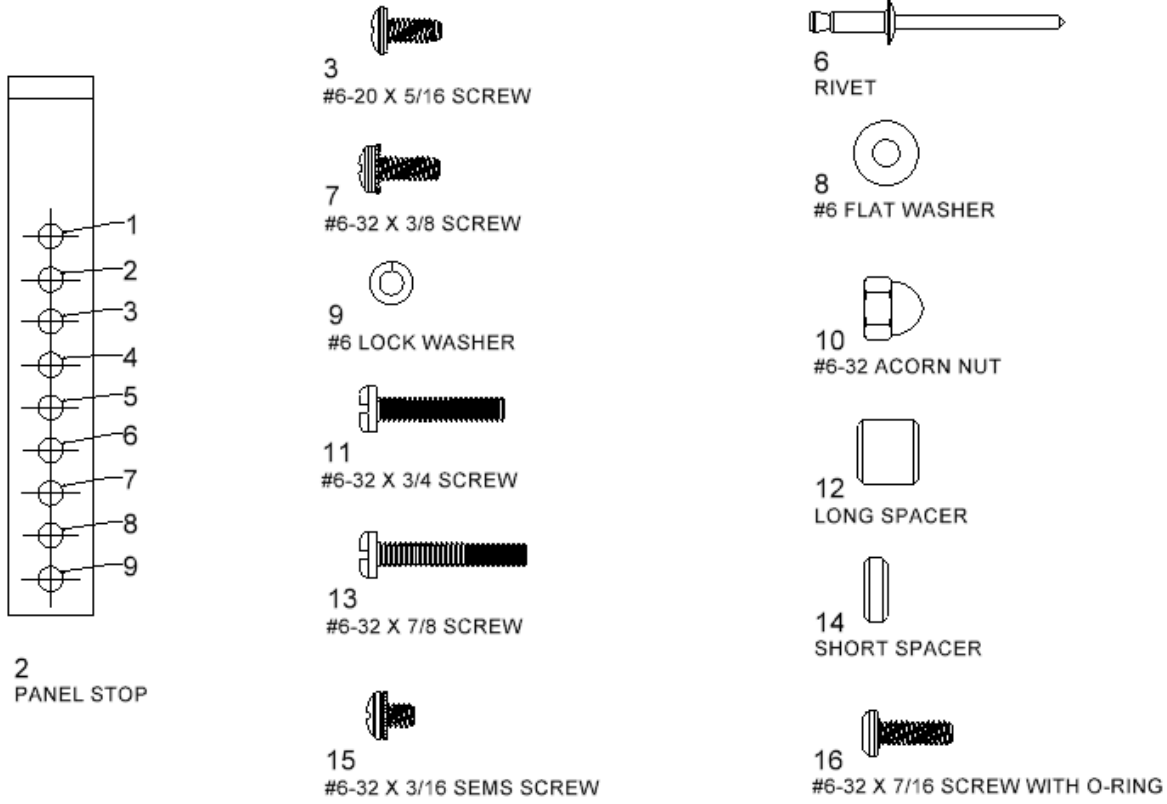



CHART A

PANEL SIZE	FOR MOUNTING FLUSH TO BOX TOP	FOR MOUNTING 1/2" ABOVE BOX	FOR MOUNTING 1/2" BELOW BOX
ALL PANELS	USE HOLES 3 AND 6	USE HOLES 5 AND 8	USE HOLES 1 AND 4



Hinge Front Panel Package Content

Component Parts List	HFP66	HFP86	HFP108	HFP120	HFP122	HFP142	HFP164	HFP186	HFP206	HFP2020	HFP2420	HFP2424	HFP3024
1.)70-60804 5" HINGE	1	1	1			2	2	2	2	2	2	2	
1.)70-805 9" HINGE				1	1								2
2.)PANEL STOP	1	1	1	2	2	2	2	2	2	2	2	2	2
3.)#6-20 X 5/16 SCREW	2	2	2	3	3	4	4	4	4	4	4	4	6
4.) FRONT PANEL P/N	SEE CHART A	SEE CHART A	SEE CHART A	SEE CHART A	SEE CHART A	SEE CHART A	SEE CHART A	SEE CHART A	SEE CHART A	SEE CHART A	SEE CHART A	SEE CHART A	SEE CHART A
5.)70-60861 SPRING LATCH	1	1	1	1	1	1	1	1	1	1	2	2	2
6.)43 316SS RIVET	2	2	2	2	2	2	2	2	2	2	4	4	4
7.)#6-32 X 3/8 SCREW	2	2	2	3	3	4	4	4	4	4	4	4	6
8.)#6 FLAT WASHER	2	2	2	3	3	4	4	4	4	4	4	4	6
9.)#6 LOCK WASHER	2	2	2	3	3	4	4	4	4	4	4	4	6
10.)#6-32 ACORN NUT	2	2	2	3	3	4	4	4	4	4	4	4	6
11.)#6-32 X 3/4 SCREW	2	2	2	3	3	4	4	4	4	4	4	4	6
12.)LONG SPACER	2	2	2	3	3	4	4	4	4	4	4	4	6
13.)#6-32 X 7/8 SCREW	2	2	2	3	3	4	4	4	4	4	4	4	6
14.)SHORT SPACER	2	2	2	3	3	4	4	4	4	4	4	4	6
15.)#6-32 X 3/16 SEMS SCREW	2	2	2	3	3	4	4	4	4	4	4	4	6
16.)#6-32 X 7/16 SCREW W/O-RING	2	2	2	4	4	4	4	4	4	4	4	4	4

CHART "A"

HINGED FRONT PANEL KIT	FRONT PANEL P/N
HFP66	70-60820HFP-1
HFP86	70-60821HFP-1
HFP108	70-60829-1
HFP120	70-60830-1
HFP122	70-HFP122PC-1
HFP142	70-60831-1
HFP164	70-60832-1
HFP186	70-60833-1
HFP206	70-60834-1
HFP2020	70-HFP2020-1
HFP2420	70-60840-1
HFP2424	70-60839-1
HFP3024	70-60838-1