

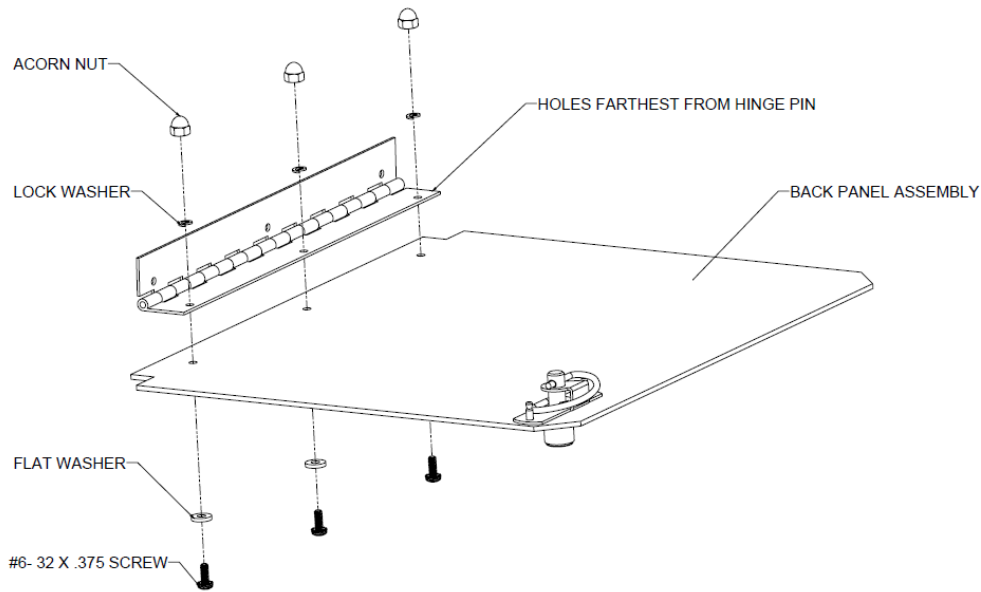

**Instructions for Installing ULTRALINE® Hinge Front Panel Kits**

**Step #1: Attach hinge(s) to panel assembly as shown.**

1. Position panel assembly with protective covering down.
2. Attach panel assembly to hinge (s) as shown in image below.



**Step #2: Drilling holes for HFP mounting.**

1. Position drill guide to the outside of the box as shown. Drill guide(s) will be used again in step #3.
2. Drill the #29 (.136") diameter holes.

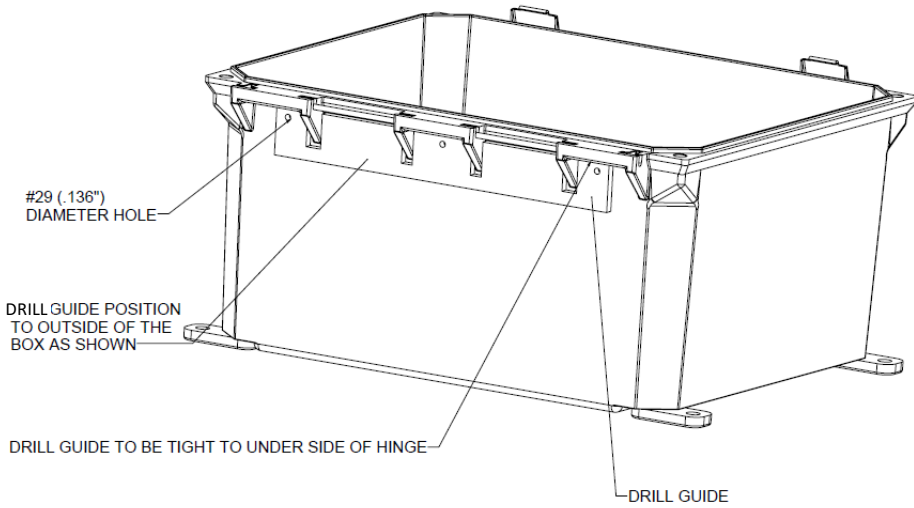



**Instructions for Installing ULTRALINE® Hinge Front Panel Kits**

**Step #3: Attach HFP to enclosure along with panel stops.**

1. Place nylon washer onto #6-32 x 3/4 screw and insert through the wall of box.
2. Place drill guide as a spacer between the box wall and the hinge.
3. Attach panel stops with (2) #10-32 x 7/16 screws. Panel stops should rest against the inside wall of the box.

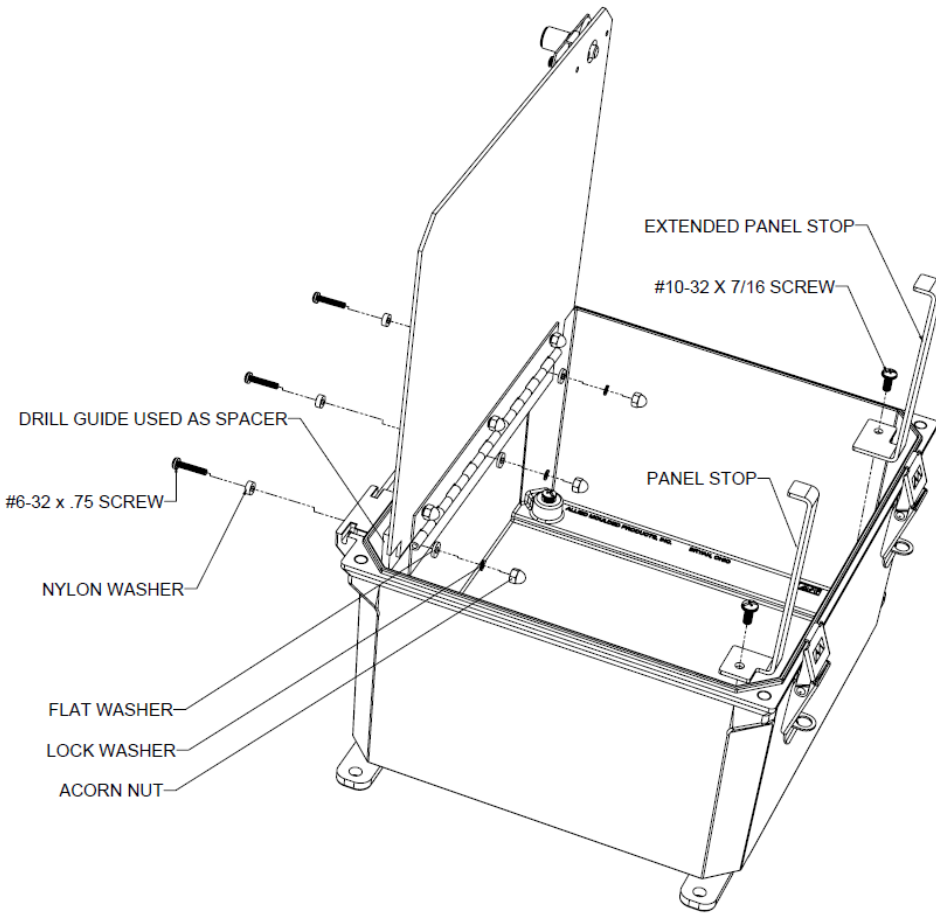

PARTS LIST					
Part Number	HFPU120	HFPU142	HFPU164	HFPU186	HFPU206
HINGE	1	2	2	2	2
PANEL ASSEMBLY	1	1	1	1	1
LATCH	1	1	1	1	1
RIVETS	2	2	2	2	2
PANEL STOP	1	1	1	1	1
EXT PANEL STOP	1	1	1	1	1
DRILL GUIDE	1	2	2	2	2
NYLON WASHER	3	4	4	4	4
LOCK WASHER	6	8	8	8	8
ACORN NUT	6	8	8	8	8
#6-32 X 7/16 SCREW	2	2	2	2	2
WASHER FLAT	6	8	8	8	8
#6-32 X 3/4 SCREW	3	4	4	4	4

**Allied Moulded Products, Inc.**  
222 North Union Street • Bryan, OH 43506  
Phone: 1-800-722-2679 • Fax: 1-800-237-7269  
[www.alliedmoulded.com](http://www.alliedmoulded.com)