

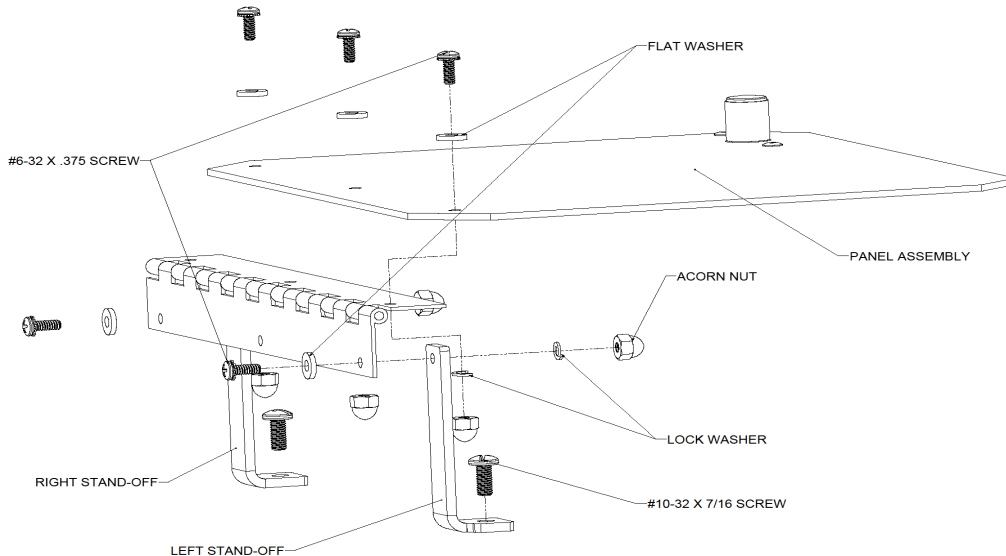

Instructions for Installing ULTRALINE® Hinge Front Panel Kits

Step #1: Attach hinge(s) to panel assembly as shown.

1. Position panel assembly as shown in image below.
2. Attach panel assembly to hinge (s) as shown in image below.



Step #2: Directions for HFP mounting.

1. Position panel stops as shown below to attach panel assembly to box
2. Use (4) #10-32 7/16 screws to attach panel stops to box.

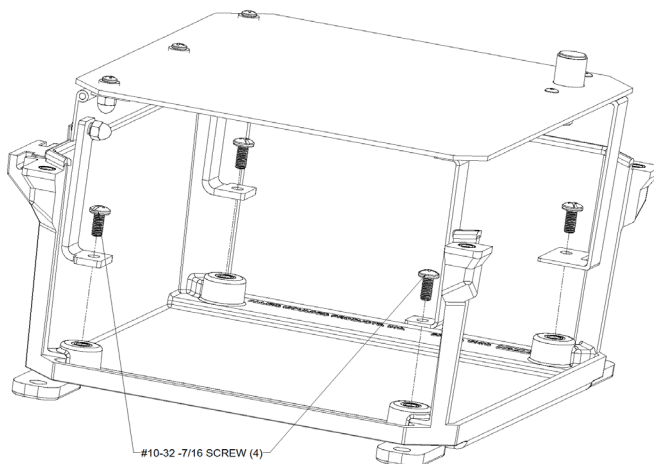

PARTS LIST				
Part Number	HFPU66	HFPU86	HFPU88	HFPU108
HINGE	1	1	1	1
PANEL ASSEMBLY	1	1	1	1
LATCH	1	1	1	1
RIVETS	2	2	2	2
PANEL STOP	1	1	1	1
EXT PANEL STOP	1	1	1	1
RIGHT STAND-OFF	1	1	1	1
LEFT STAND-OFF	1	1	1	1
ACORN NUT	5	5	5	5
FLAT WASHER	5	5	5	5
#6-32 X 3/8 SCREW	5	5	5	5
LOCK WASHER	5	5	5	5
#10-32 X 3/4 SCREW	4	4	4	4

Allied Moulded Products, Inc.
222 North Union Street • Bryan, OH 43506
Phone: 1-800-722-2679 • Fax: 1-800-237-7269
www.alliedmoulded.com