

OPTIONAL BACK PANEL
 0.100 [2.54] TH'K- ALUMINUM
 0.075 [1.91] TH'K- WHITE STEEL & GALVANNEALED
 0.125 [3.18] TH'K- FIBERGLASS

(2) POLYCARBONATE
 FLANGES (GLUED)

(4) EACH #10-32 BRASS
 INSERTS, AND STAINLESS
 STEEL FLANGE AND
 FEET SCREWS

(12) R.162 [4.10]

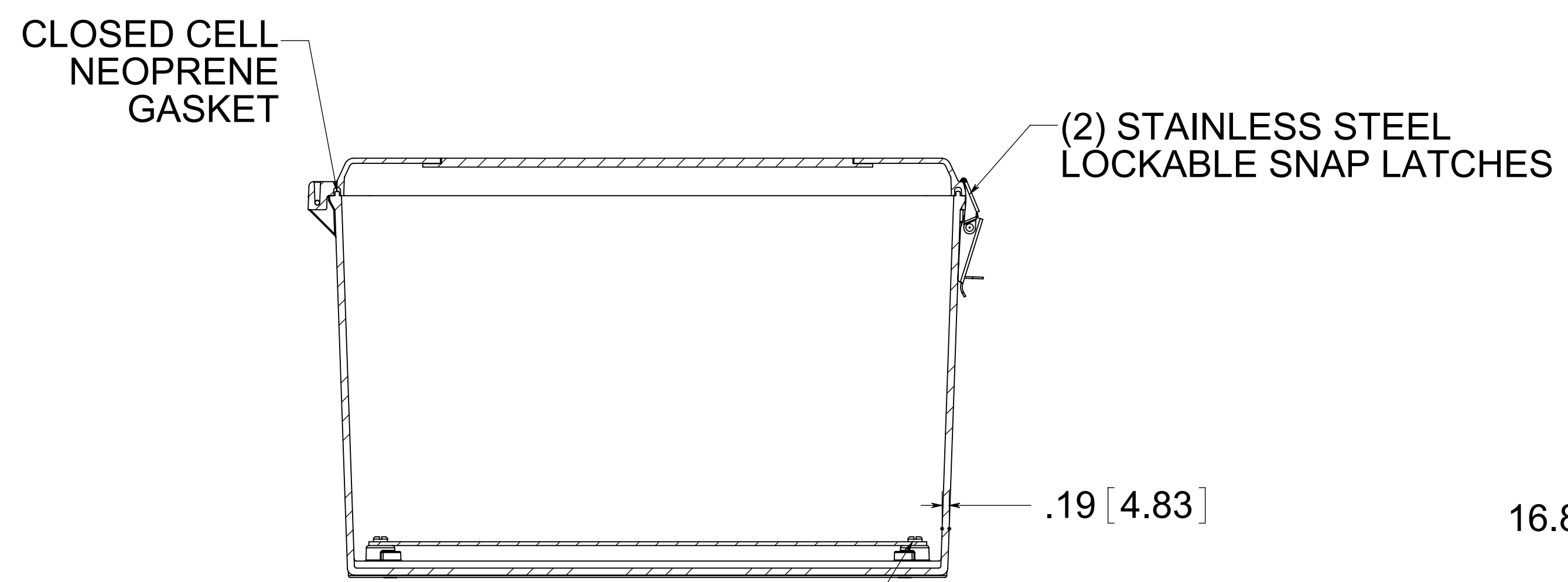
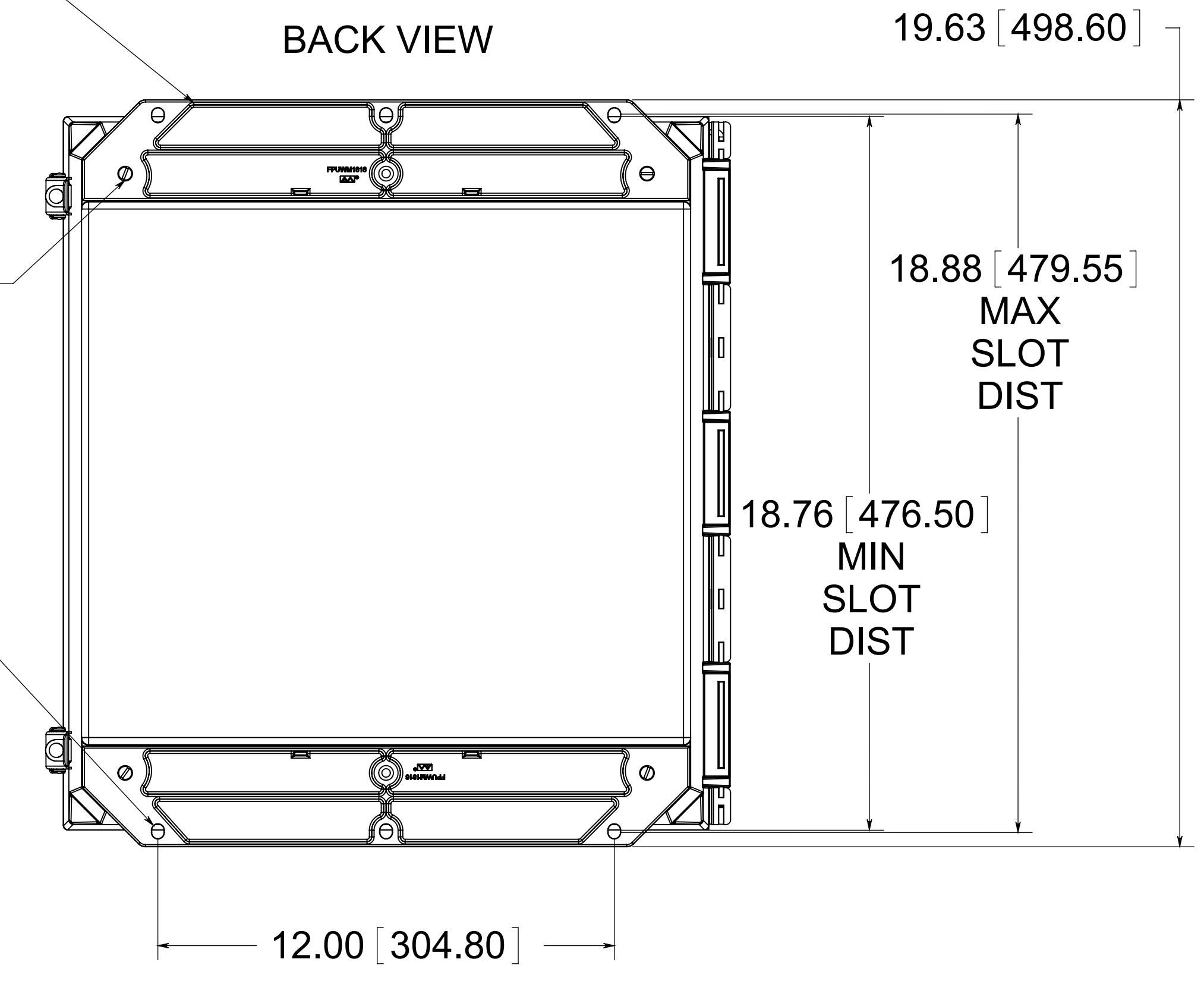

(4) EACH #10-32 BRASS
 INSERTS AND PLATED
 CARBON STEEL SCREWS

FRONT VIEW
 WITH COVER REMOVED
 AND BACK PANEL DISPLAYED

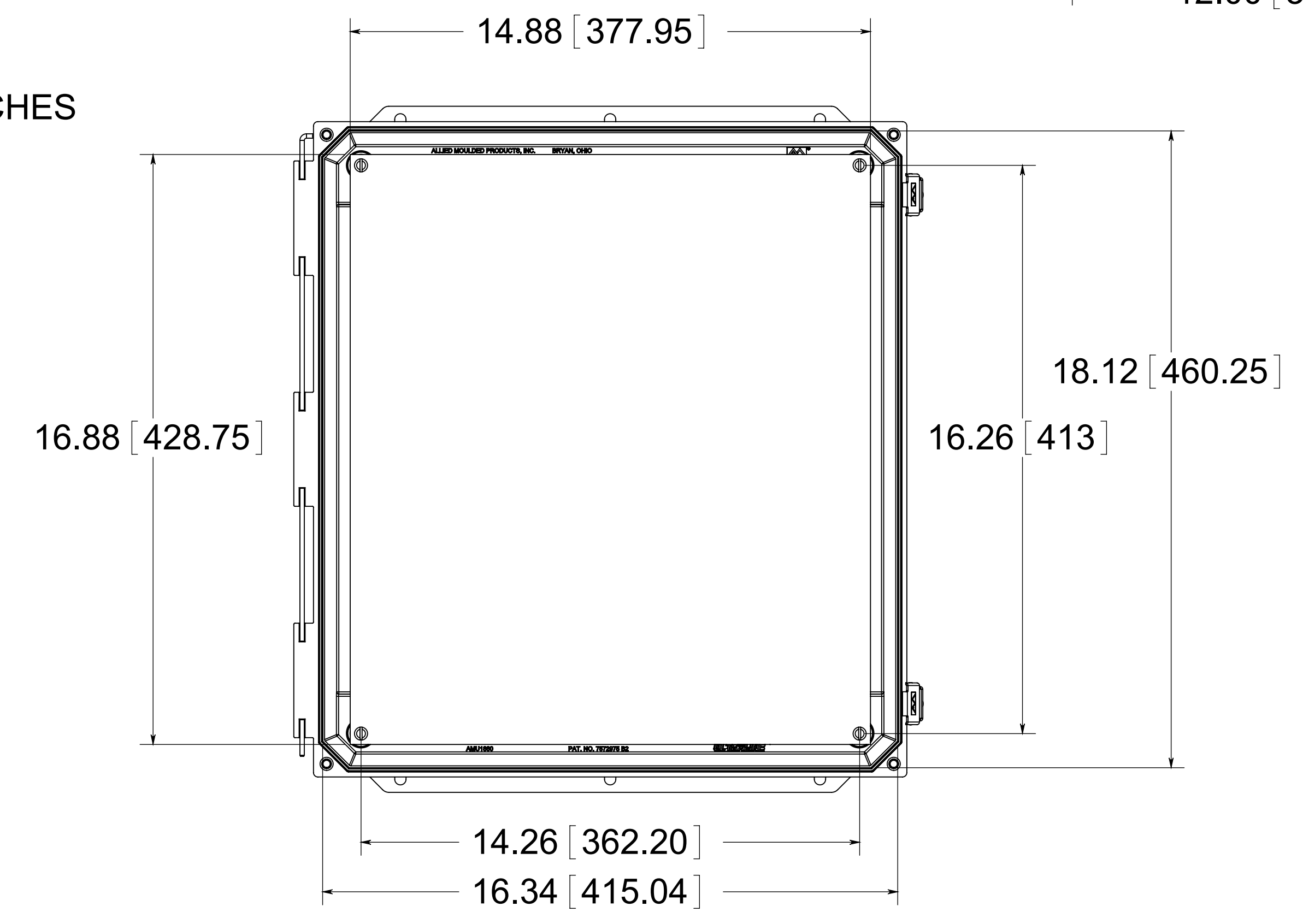

MATERIAL:
 BOX- COMPRESSION MOLDED FIBERGLASS REINFORCED POLYESTER
 COVER- COMPRESSION MOLDED FIBERGLASS REINFORCED POLYESTER
 WINDOWS- POLYCARBONATE

CONFIDENTIAL
 THIS MATERIAL IS OWNED BY THE ALLIED
 MOULDED PRODUCTS COMPANY, IS DISCLOSED
 IN CONFIDENCE, AND IS NOT TO BE REPRODUCED
 OR DISTRIBUTED WITHOUT PRIOR WRITTEN
 PERMISSION FROM ALLIED MOULDED PRODUCTS.

ALLIED MOULDED PRODUCTS
 BRYAN, OHIO
 The Original Fiber Glass Outlet Box

Description
AMU Ultraline
 Part No.
AMU1860LWF