

(2X) EACH #10-32 BRASS INSERTS AND 316 STAINLESS CAPTIVE COVER SCREWS

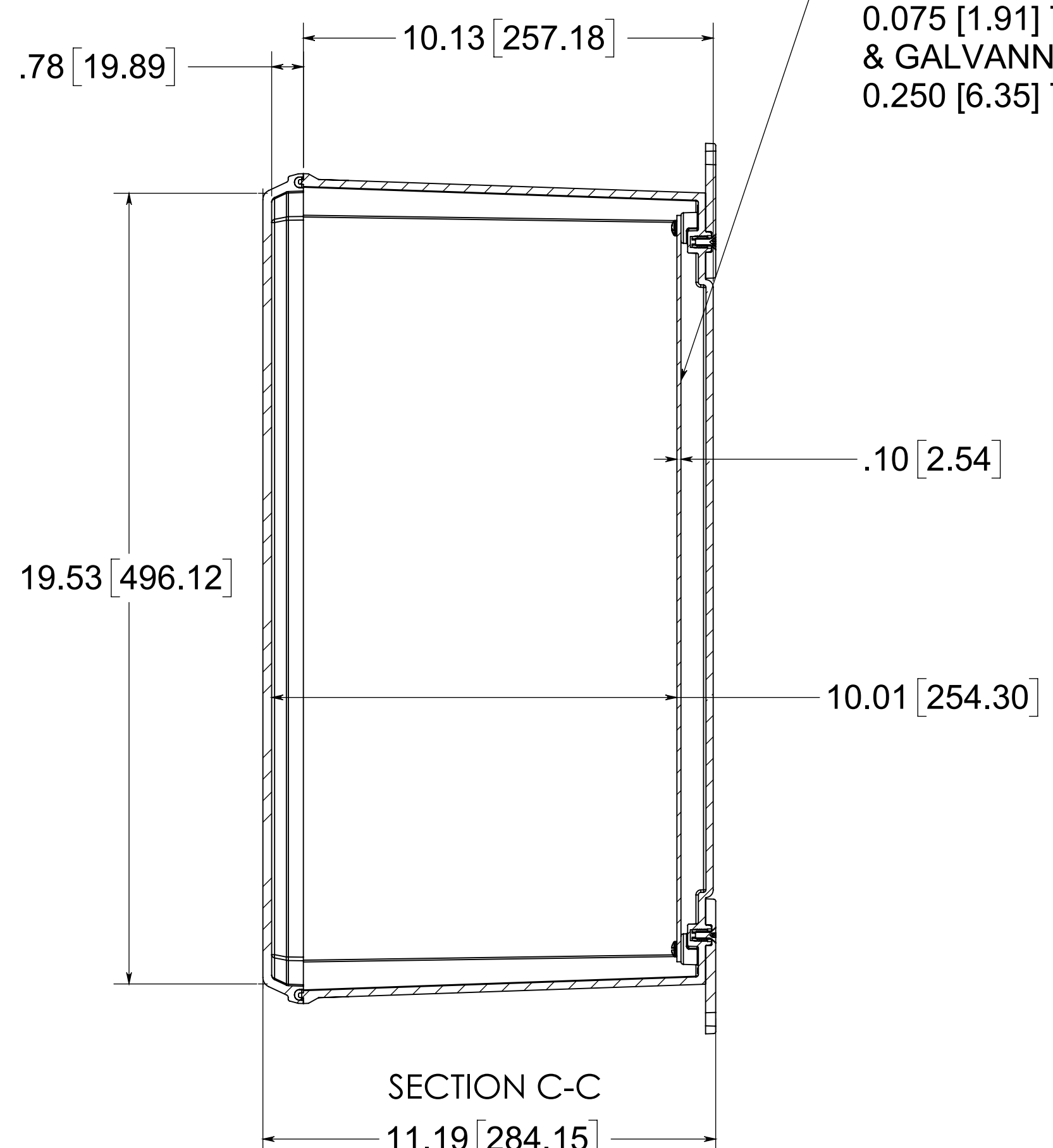

SECTION C-C

OPTIONAL BACK PANEL  
 0.100 [2.54] TH'K - ALUMINUM  
 0.075 [1.91] TH'K - WHITE STEEL & GALVANNEALED  
 0.250 [6.35] TH'K - FIBERGLASS

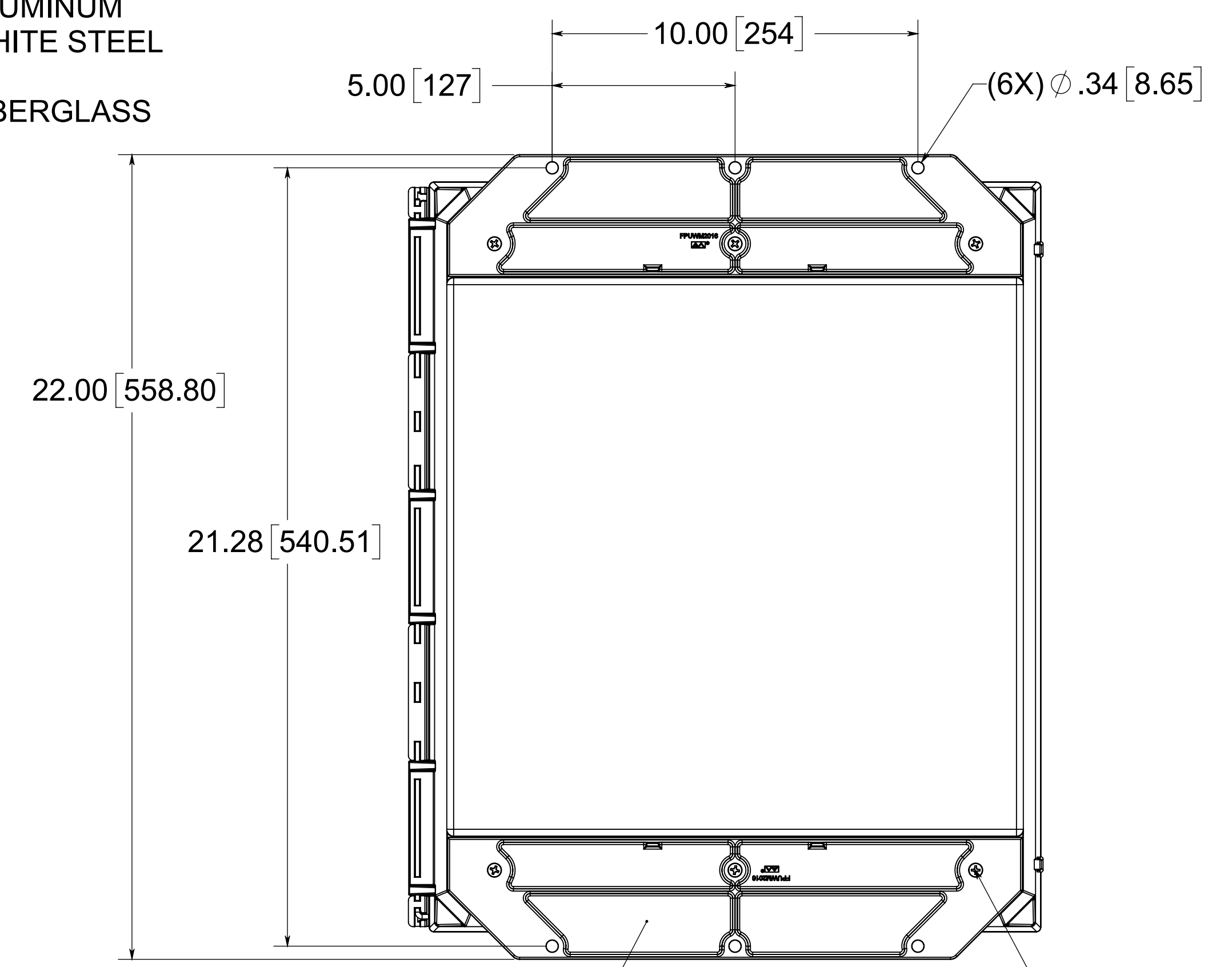

(2X) POLYCARBONATE FLANGES

(6X) EACH #10-32 BRASS INSERTS AND 316 STAINLESS STEEL FLANGE AND FEET SCREWS

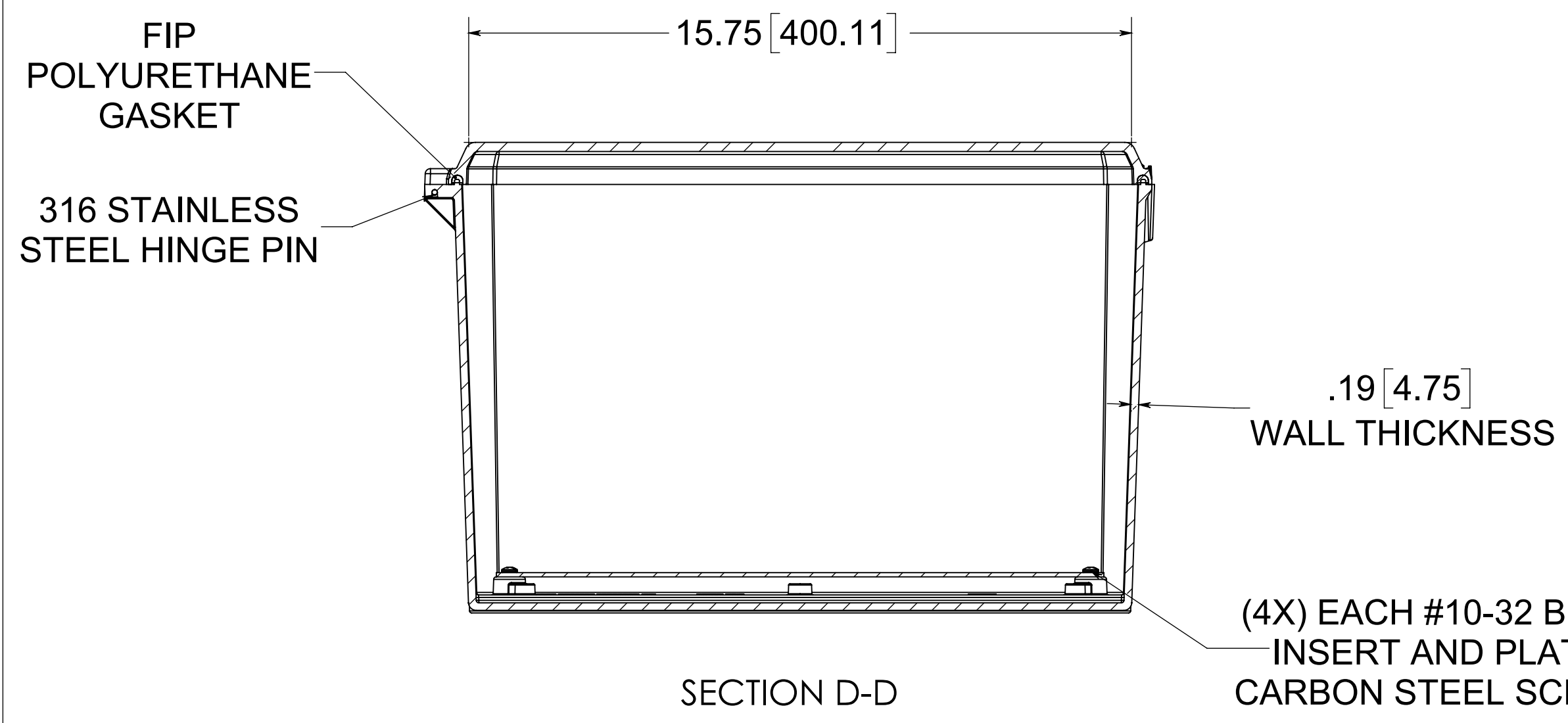

SECTION D-D

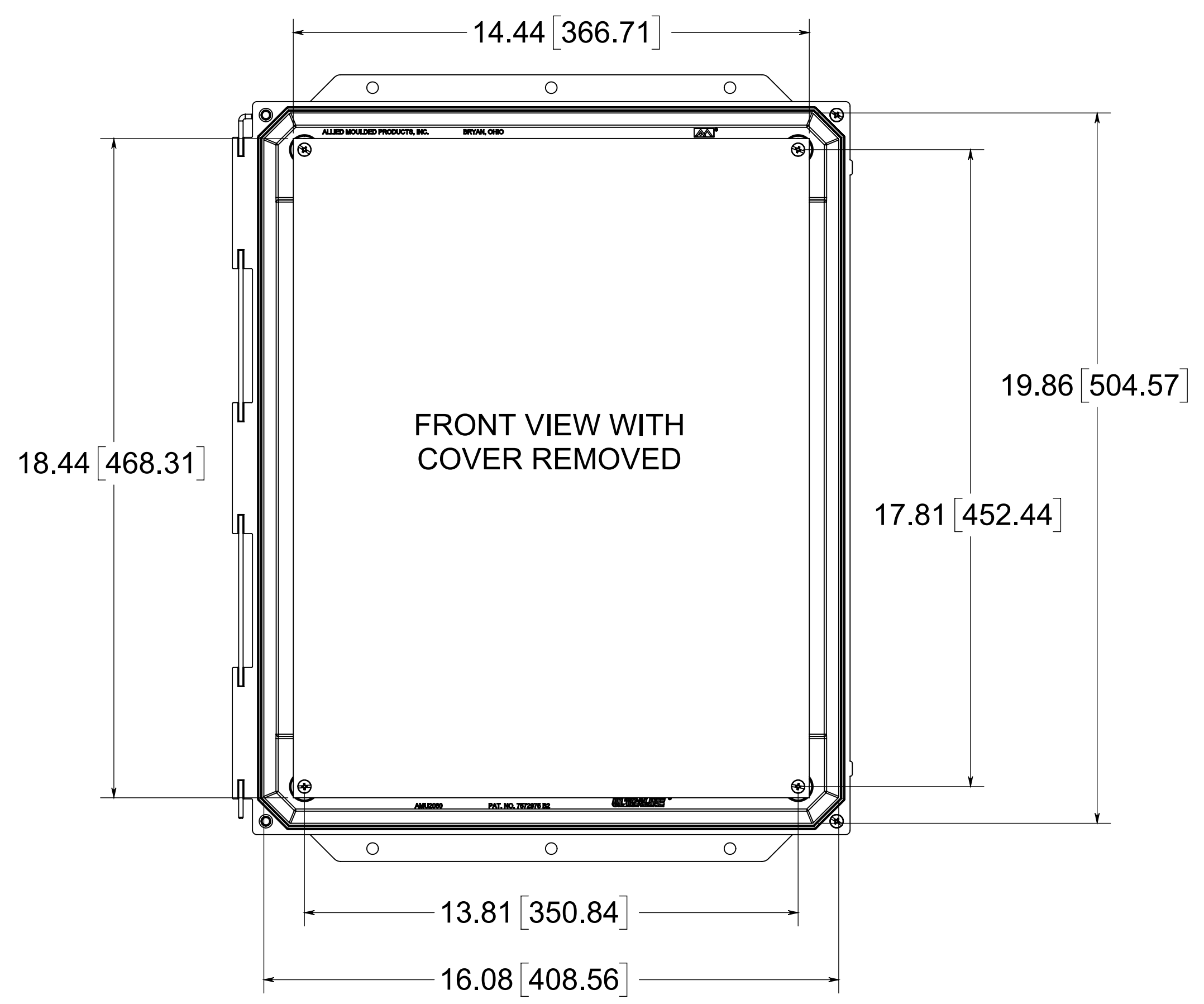

FRONT VIEW WITH COVER REMOVED

**MATERIAL:**  
 BOX: INJECTION MOLDED POLYCARBONATE  
 STANDARD COVER: INJECTION MOLDED POLYCARBONATE  
 CLEAR COVER: INJECTION MOLDED POLYCARBONATE

NOTE:  
 1. DATA SUBJECT TO CHANGE

**CONFIDENTIAL**  
 THIS MATERIAL IS OWNED BY THE ALLIED MOULDED PRODUCTS COMPANY, IS DISCLOSED IN CONFIDENCE, AND IS NOT TO BE REPRODUCED OR DISTRIBUTED WITHOUT PRIOR WRITTEN PERMISSION FROM ALLIED MOULDED PRODUCTS.  
 © Allied Moulded Products, Inc. All Rights Reserved

ALLIED MOULDED PRODUCTS  
 BRYAN, OHIO  
 The Original Fiber Glass Outlet Box

Description  
**AMU Ultraline**  
 Part No.  
**AMU2060CCHF**