

(4X) EACH #10-32 BRASS INSERTS AND 316 STAINLESS STEEL CAPTIVE COVER SCREWS

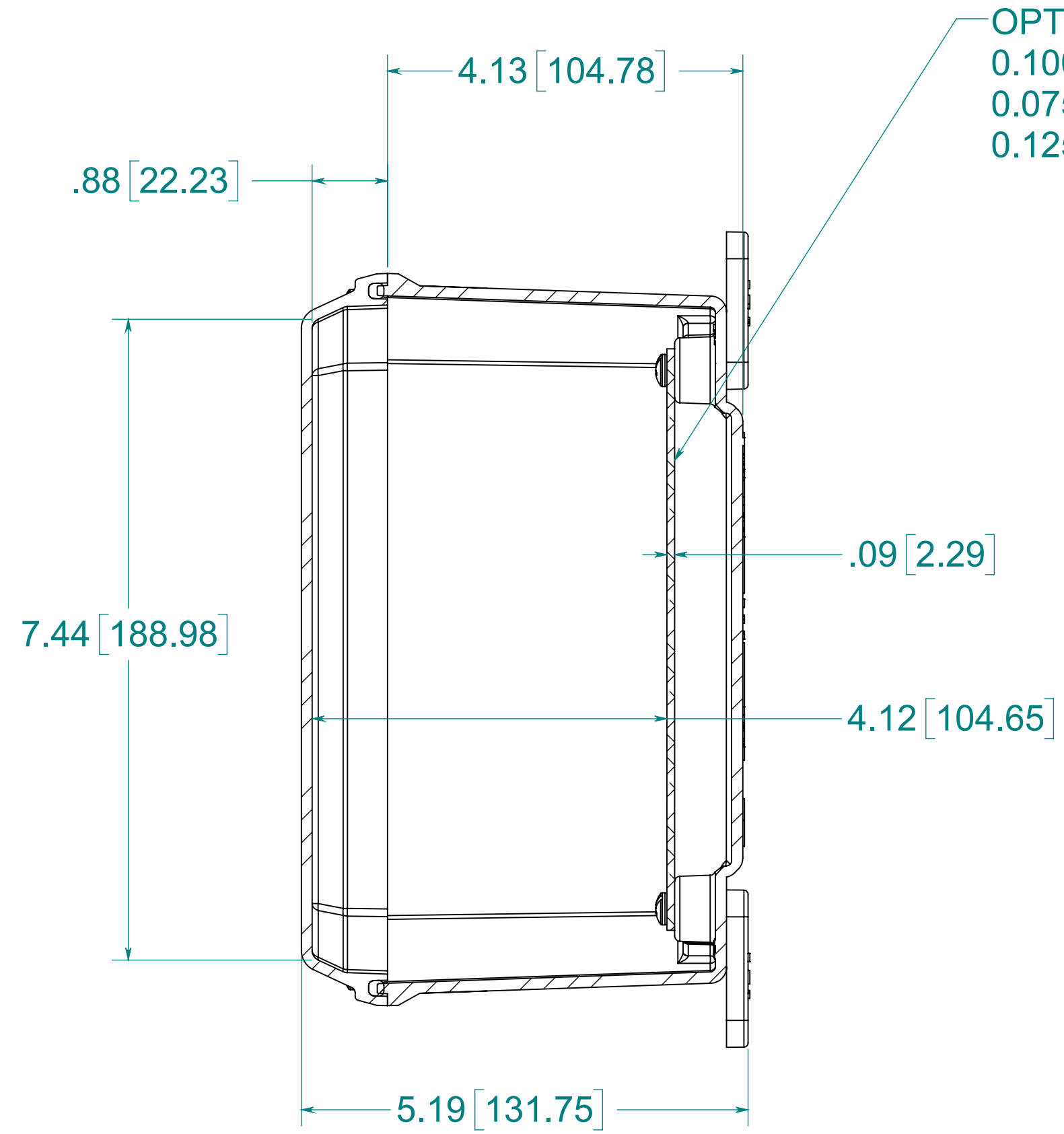

SECTION A-A

OPTIONAL BACK PANEL  
 0.100 [2.54] TH'K- ALUMINUM  
 0.075 [1.91] TH'K- WHITE STEEL  
 0.125 [3.18] TH'K- FIBERGLASS

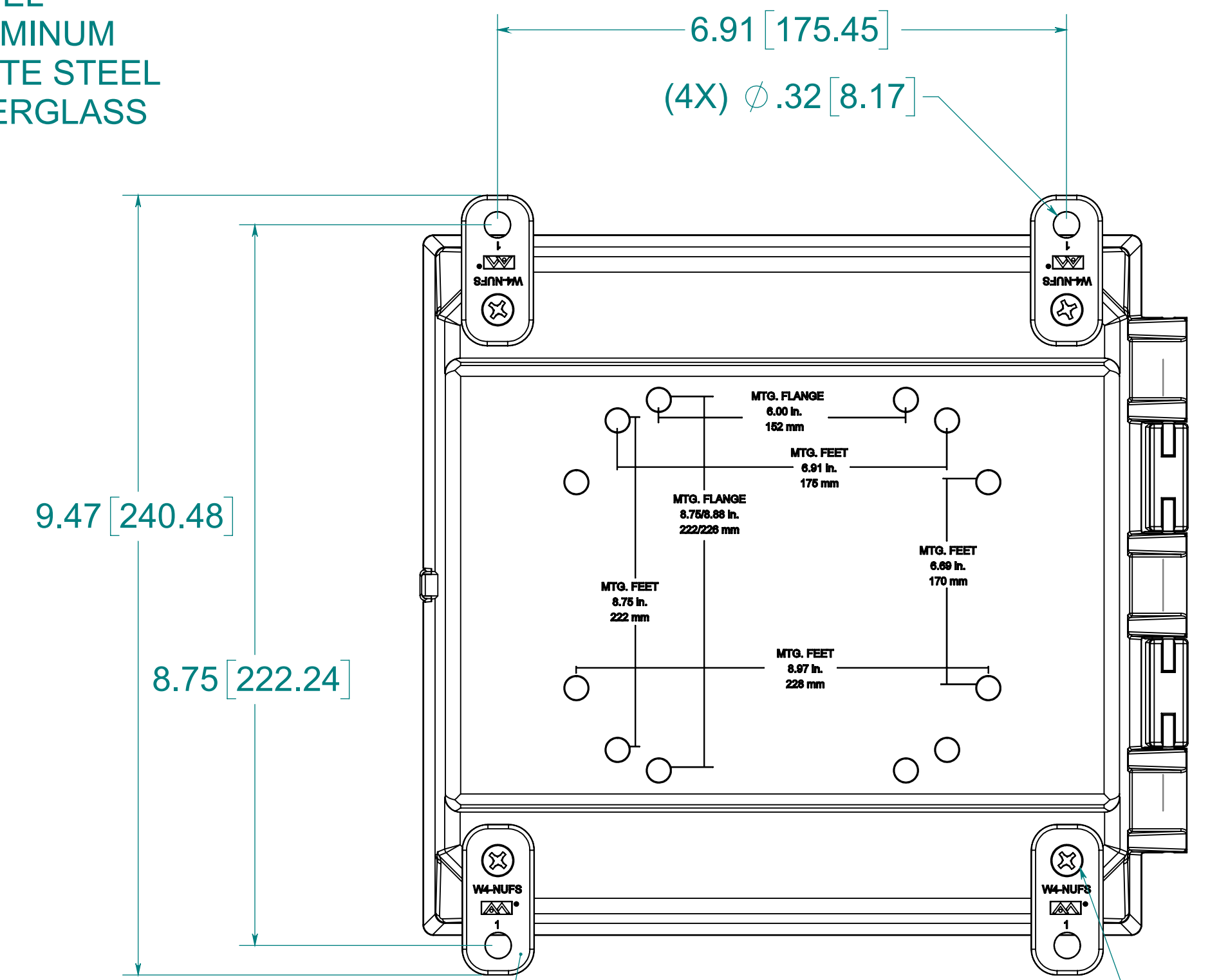

(4X) POLYCARBONATE FEET

(4X) EACH #10-32 BRASS INSERTS AND 316 STAINLESS STEEL FEET SCREWS

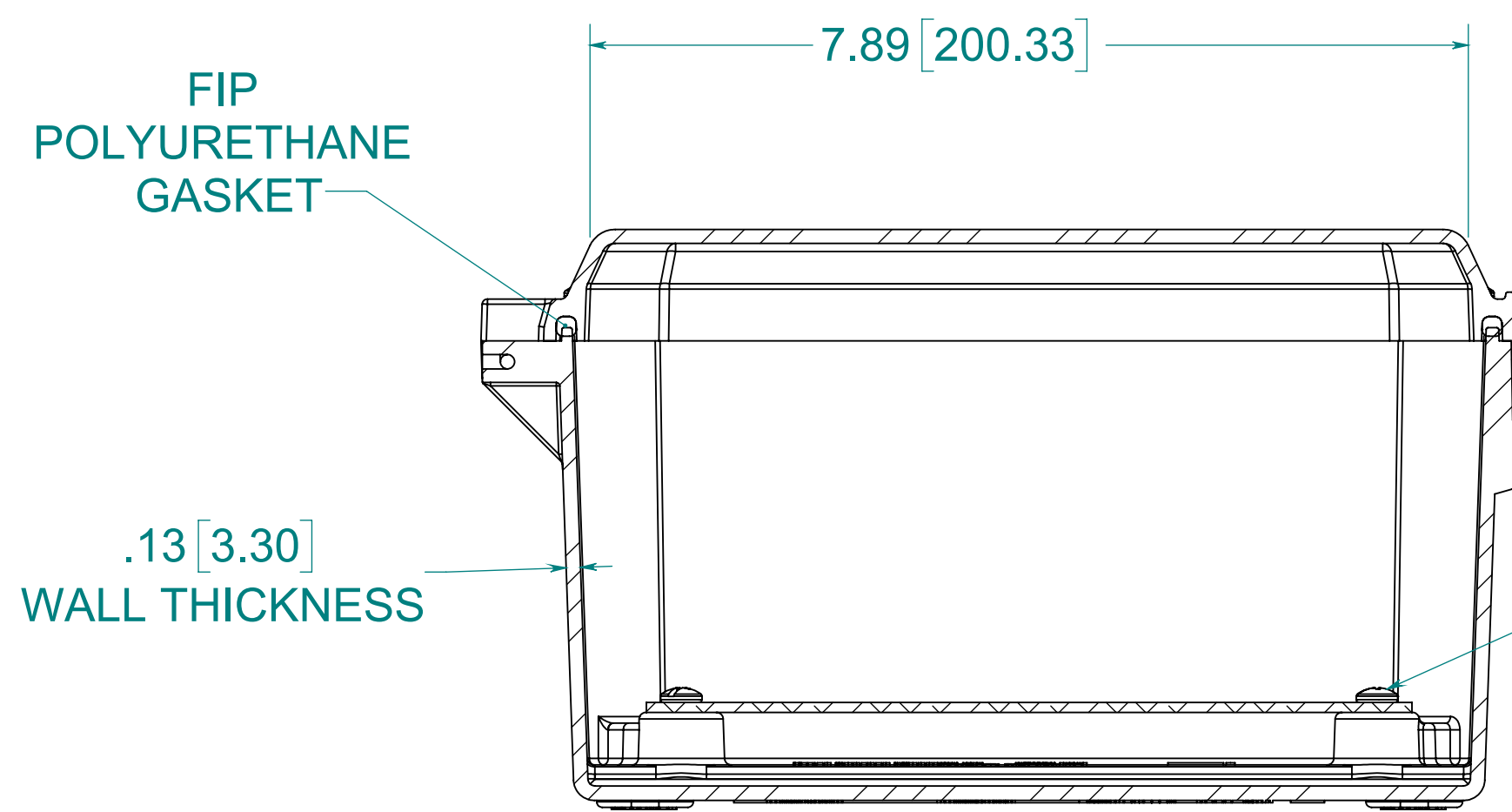

SECTION B-B

(4X) EACH #10-32 BRASS INSERTS AND PLATED CARBON STEEL SCREW

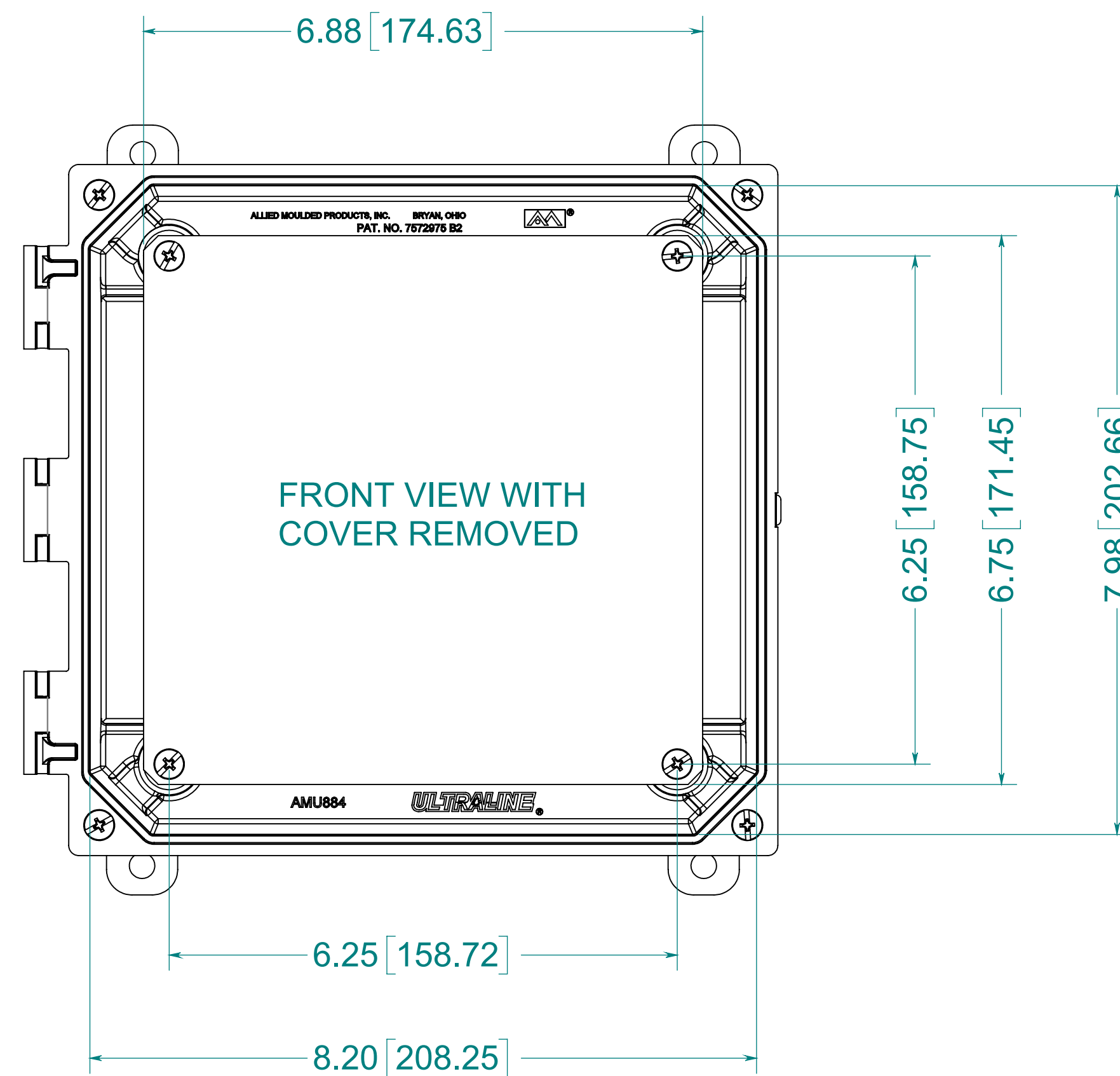

FRONT VIEW WITH COVER REMOVED

NOTE:  
 DATA SUBJECT TO CHANGE WITHOUT NOTICE

MATERIAL:  
 BOX- COMPRESSION MOLDED FIBERGLASS REINFORCED POLYESTER  
 COVER- COMPRESSION MOLDED FIBERGLASS REINFORCED POLYESTER  
 CLEAR COVER- INJECTION MOLDED POLYCARBONATE

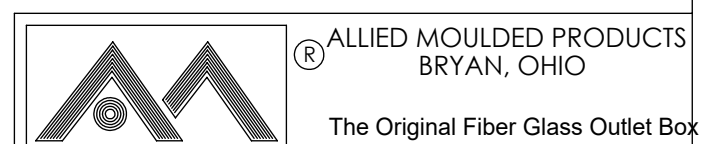

CONFIDENTIAL  
 THIS MATERIAL IS OWNED BY THE ALLIED MOULDED PRODUCTS COMPANY, IS DISCLOSED IN CONFIDENCE, AND IS NOT TO BE REPRODUCED OR DISTRIBUTED WITHOUT PRIOR WRITTEN PERMISSION FROM ALLIED MOULDED PRODUCTS.  
 © 2017 Allied Moulded Products, Inc. All Rights Reserved

Description  
 AMU Ultraline  
 Part No.  
 AMU884CC