

SECTION A-A

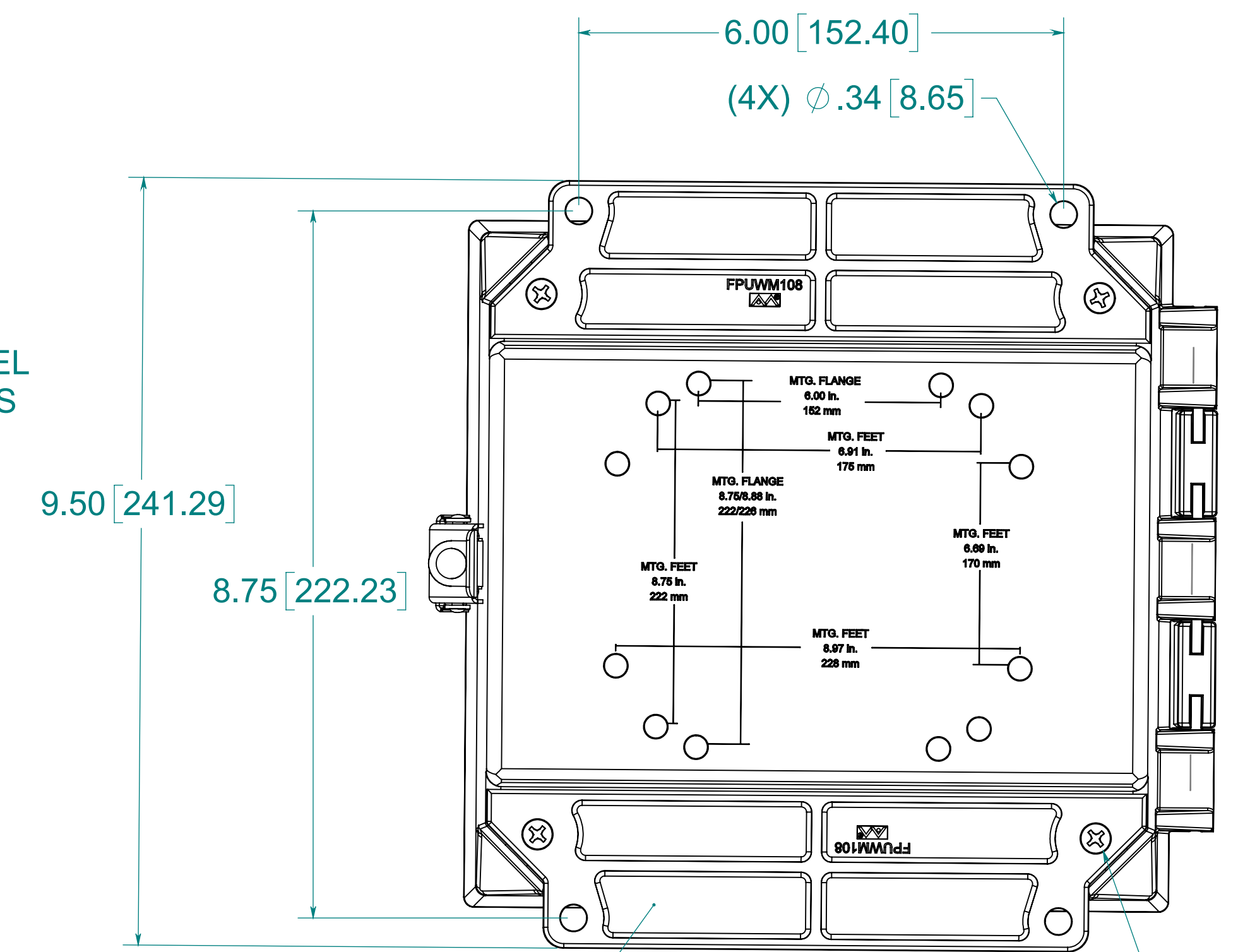

(2X) POLYCARBONATE FLANGES

(4X) EACH #10-32 BRASS INSERT AND 316 STAINLESS STEEL FLANGE SCREWS

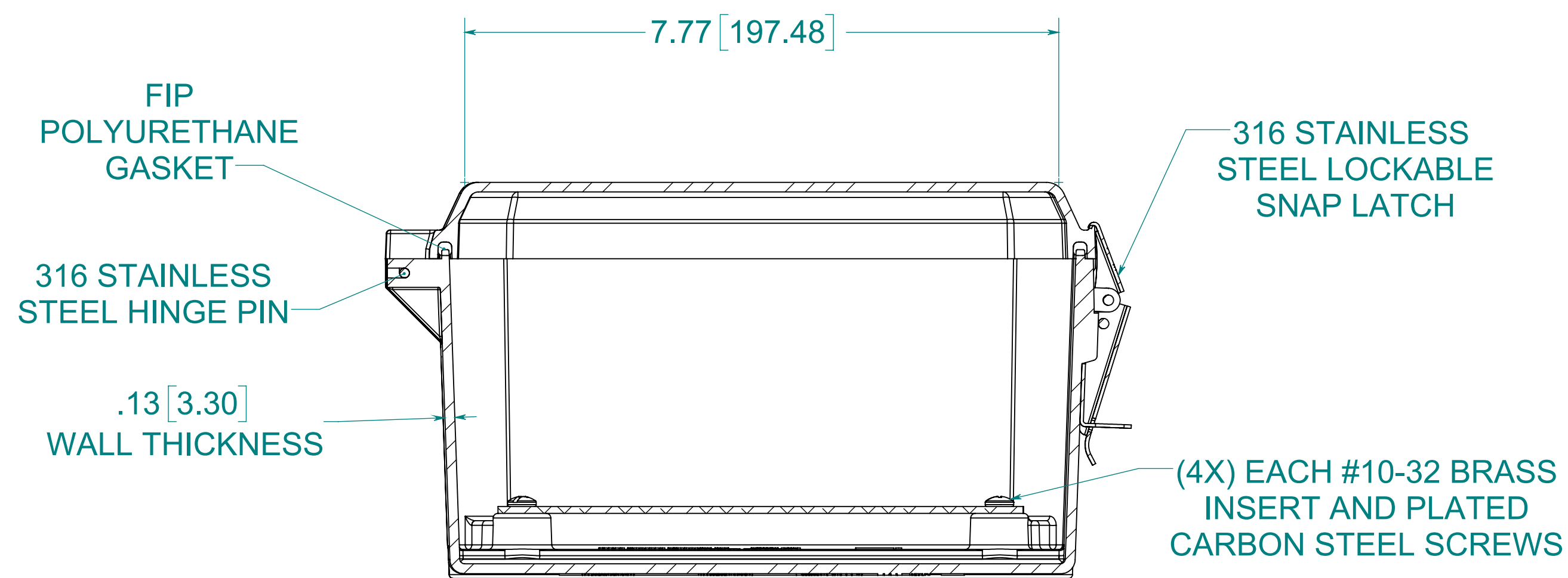

SECTION B-B

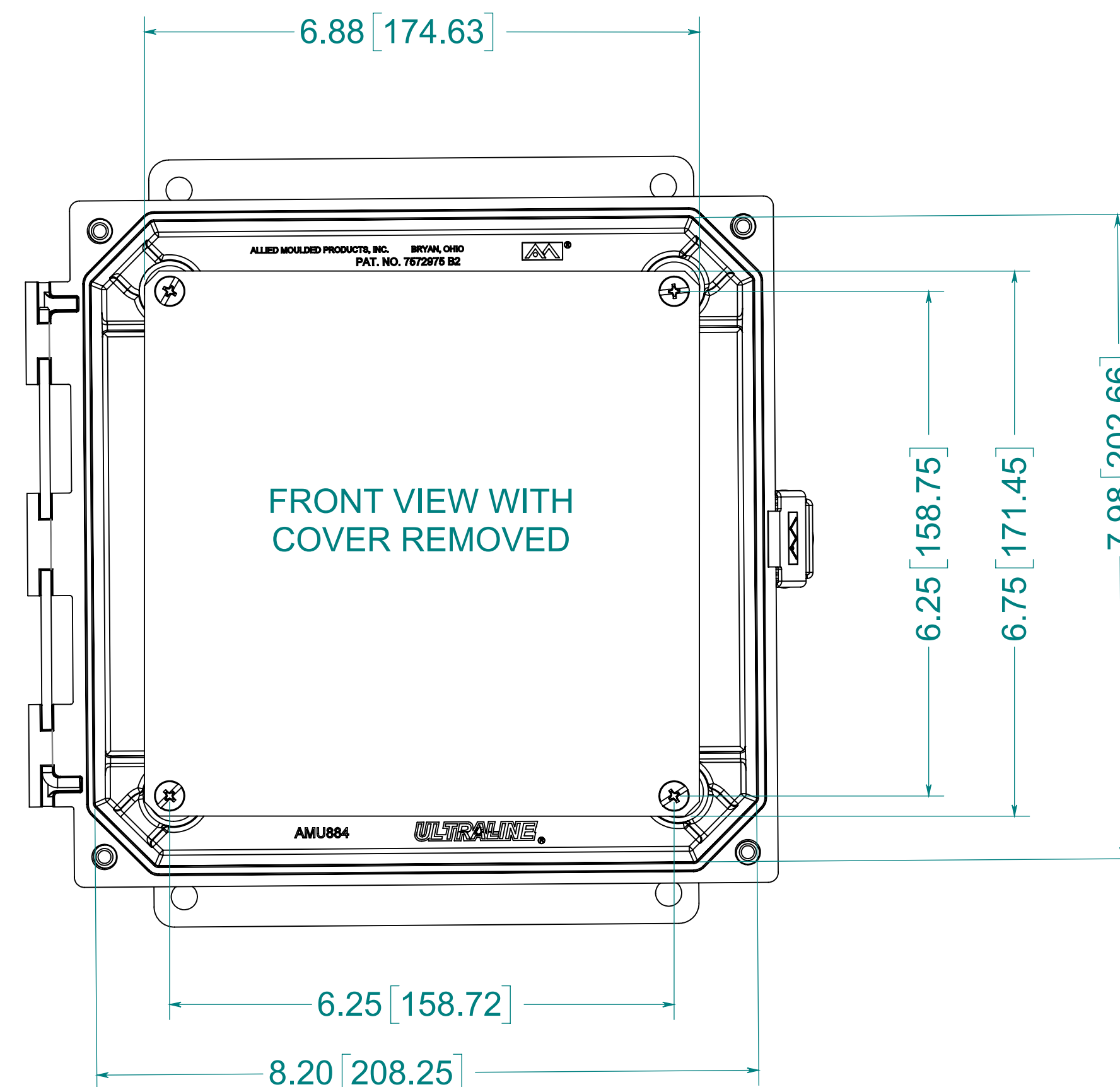

NOTE:  
 1. DATA SUBJECT TO CHNAGE WITHOUT NOTICE

**MATERIAL:**  
 BOX- COMPRESSION MOLDED FIBERGLASS REINFORCED POLYESTER  
 COVER- COMPRESSION MOLDED FIBERGLASS REINFORCED POLYESTER  
 CLEAR COVER- INJECTION MOLDED POLYCARBONATE

**CONFIDENTIAL**  
 THIS MATERIAL IS OWNED BY THE ALLIED MOULDED PRODUCTS COMPANY, IS DISCLOSED IN CONFIDENCE, AND IS NOT TO BE REPRODUCED OR DISTRIBUTED WITHOUT PRIOR WRITTEN PERMISSION FROM ALLIED MOULDED PRODUCTS.  
 © 2017 Allied Moulded Products, Inc.  
 All Rights Reserved

ALLIED MOULDED PRODUCTS  
 BRYAN, OHIO  
 The Original Fiber Glass Outlet Box

Description  
**AMU Ultraline**  
 Part No.  
**AMU884CCLF**