

(4X) #10-32 BRASS INSERTS AND 316 STAINLESS STEEL CAPTIVE COVER SCREWS

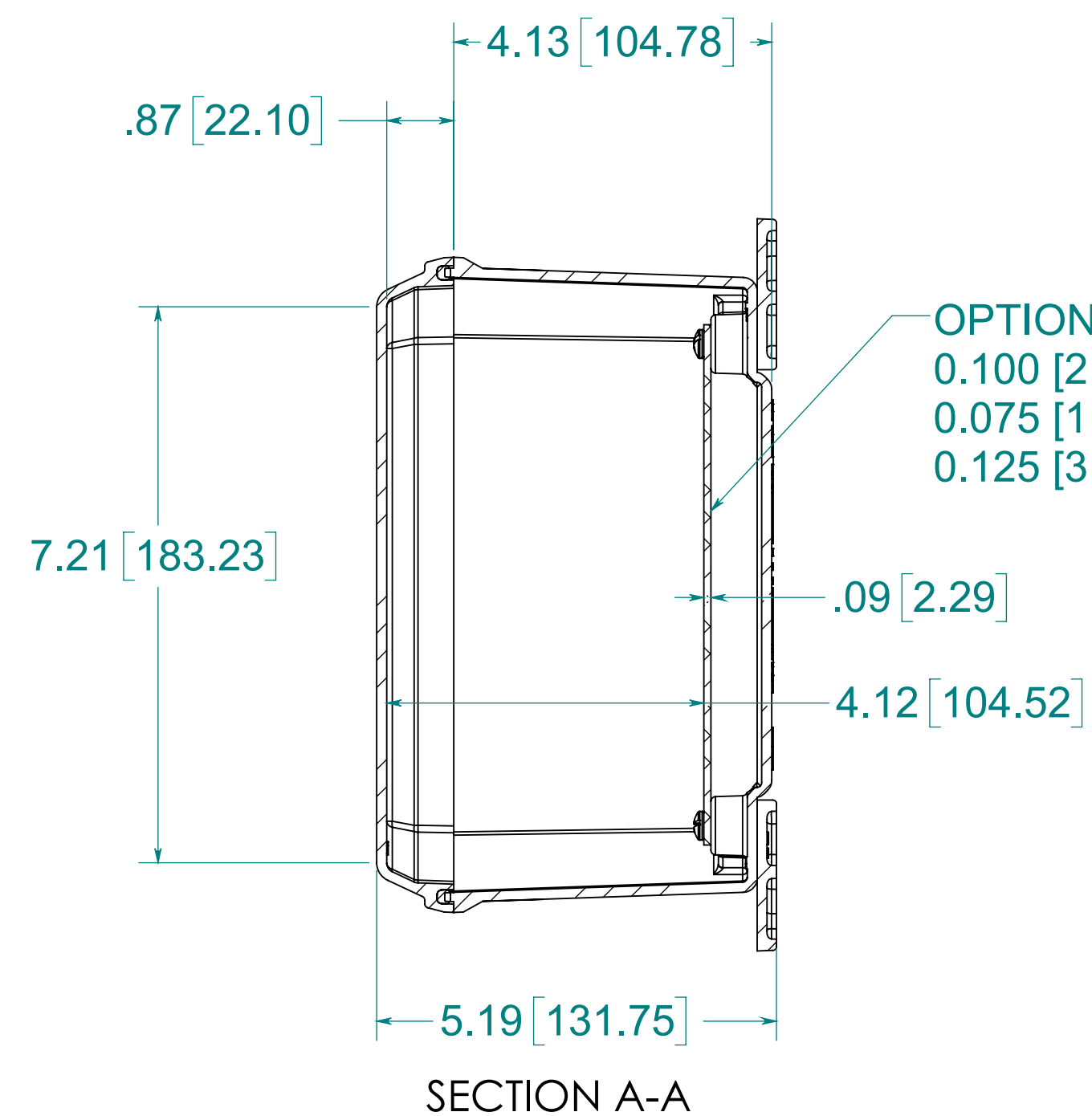

OPTIONAL BACK PANEL
 0.100 [2.54] TH'K- ALUMINUM
 0.075 [1.91] TH'K- WHITE STEEL
 0.125 [3.18] TH'K- FIBERGLASS

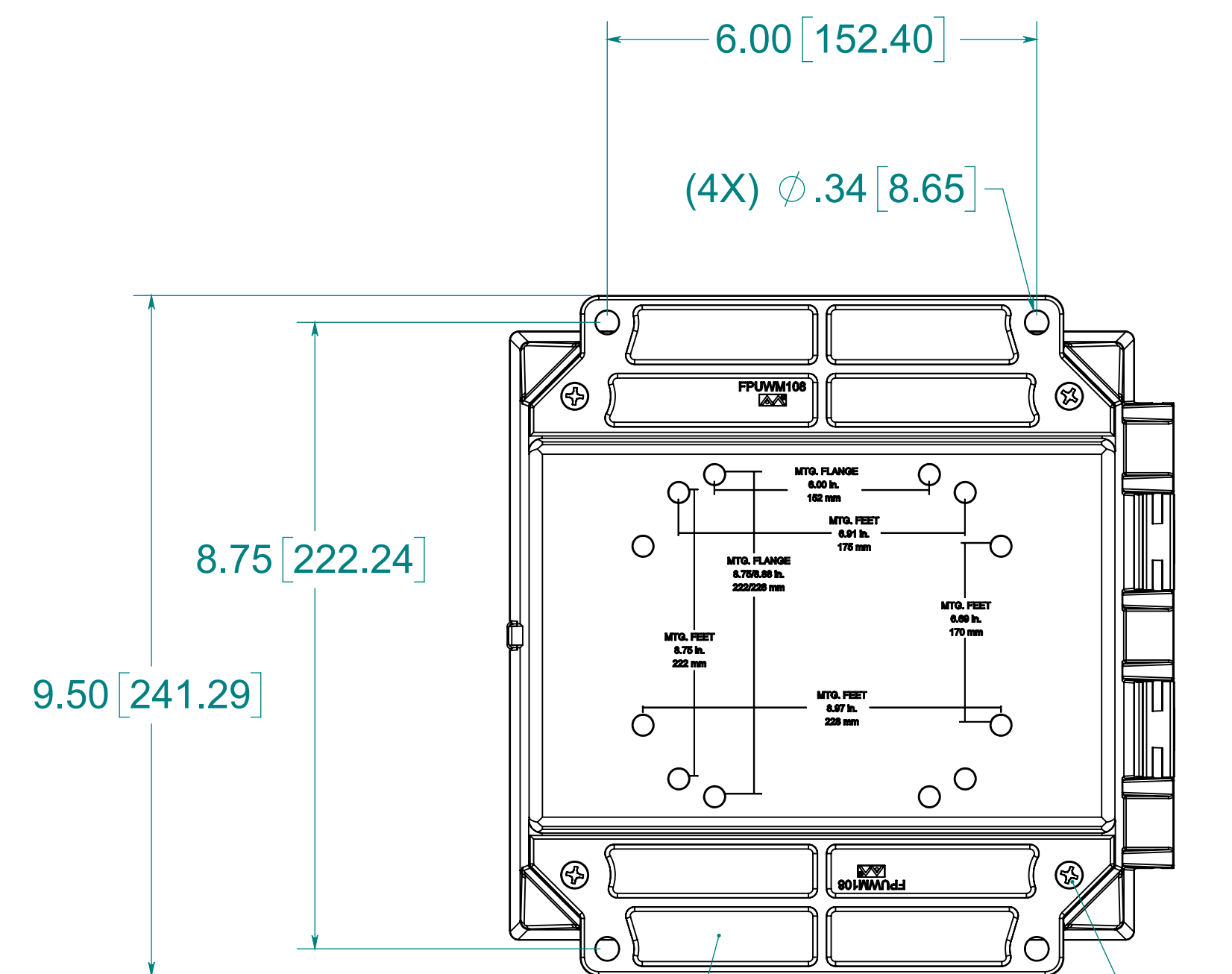

(2X) POLYCARBONATE FLANGES

(4X) EACH #10-32 BRASS INSERTS AND 316 STAINLESS STEEL FEET SCREWS

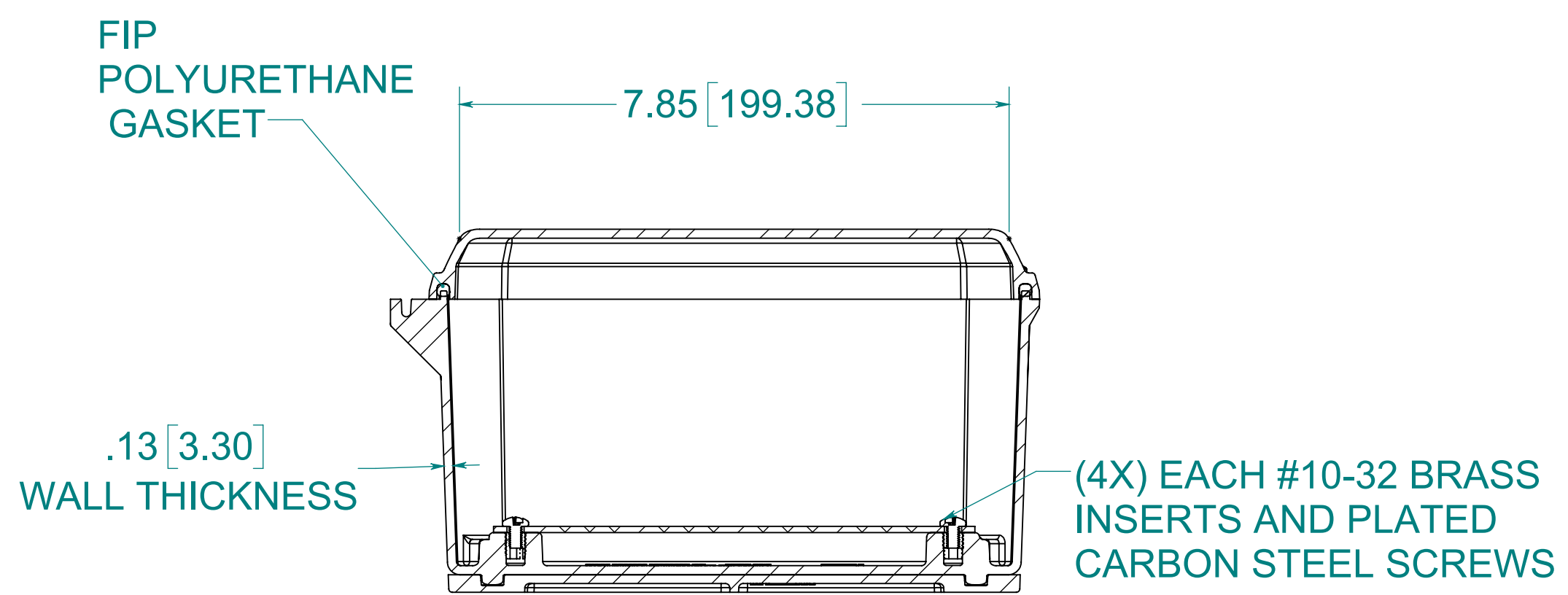

SECTION B-B

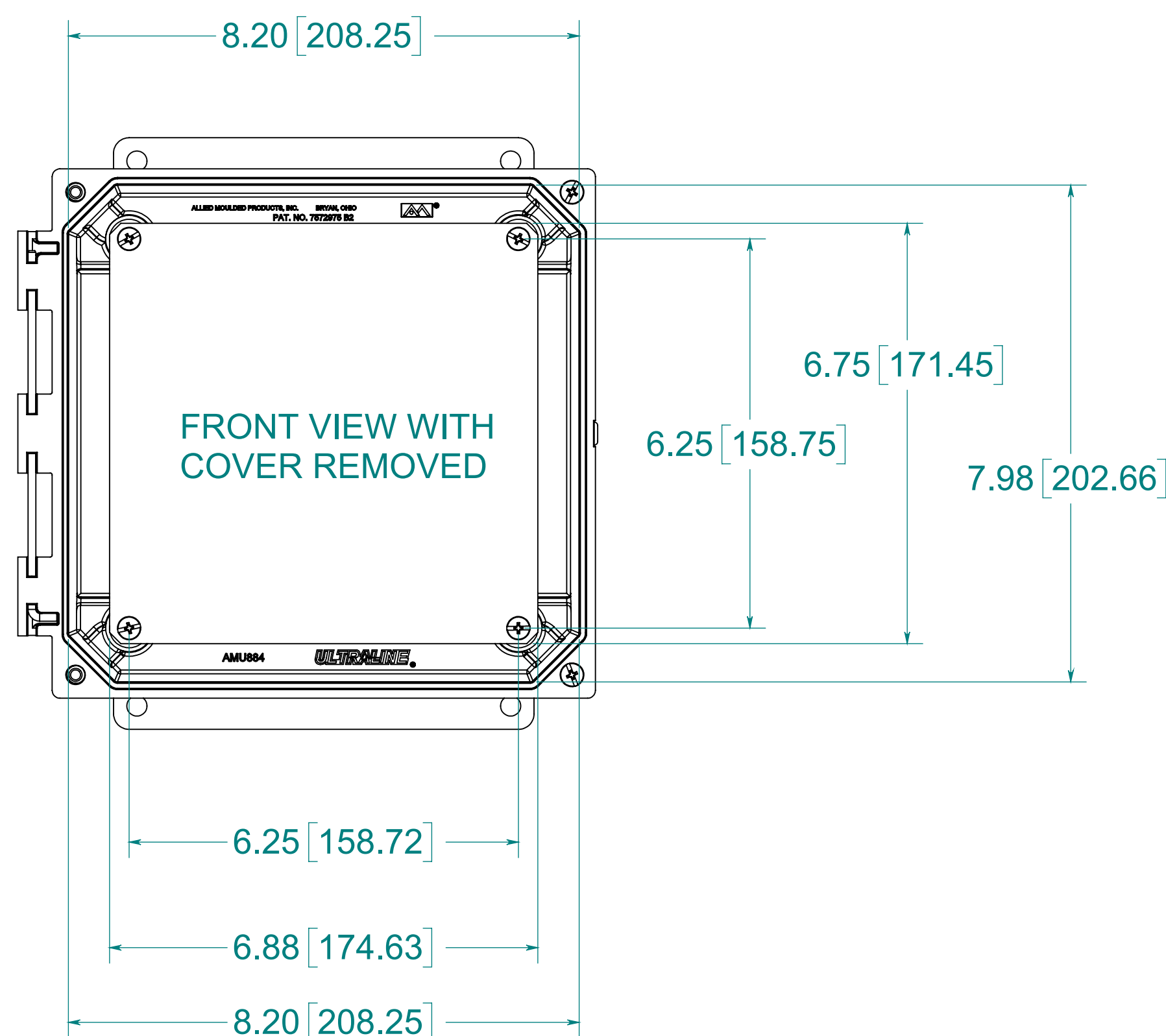

FRONT VIEW WITH COVER REMOVED

NOTE:
 DATA SUBJECT TO CHANGE WITHOUT NOTICE

MATERIAL:
 BOX- COMPRESSION MOLDED FIBERGLASS REINFORCED POLYESTER
 COVER- COMPRESSION MOLDED FIBERGLASS REINFORCED POLYESTER
 CLEAR COVER- INJECTION MOLDED POLYCARBONATE

ALLIED MOULDED PRODUCTS
 BRYAN, OHIO
 The Original Fiber Glass Outlet Box

Description	AMU Ultraline
Part No.	AMU884HF

CONFIDENTIAL
 THIS MATERIAL IS OWNED BY THE ALLIED MOULDED PRODUCTS COMPANY, IS DISCLOSED IN CONFIDENCE, AND IS NOT TO BE REPRODUCED OR DISTRIBUTED WITHOUT PRIOR WRITTEN PERMISSION FROM ALLIED MOULDED PRODUCTS.
 © 2017 Allied Moulded Products, Inc.
 All Rights Reserved