

Date	Rev	Description	ECN No.	ISSUE DATE	DR	CK	REL
11/09/2021	01	NOTCHED LATCH BOSS	ECN-1427		DJL	BFB	GEL
07/06/2018	ERRO	INITIAL RELEASE	ECN-12615		DJL	SRH	GEL
-	Revision	-	-		-	-	-

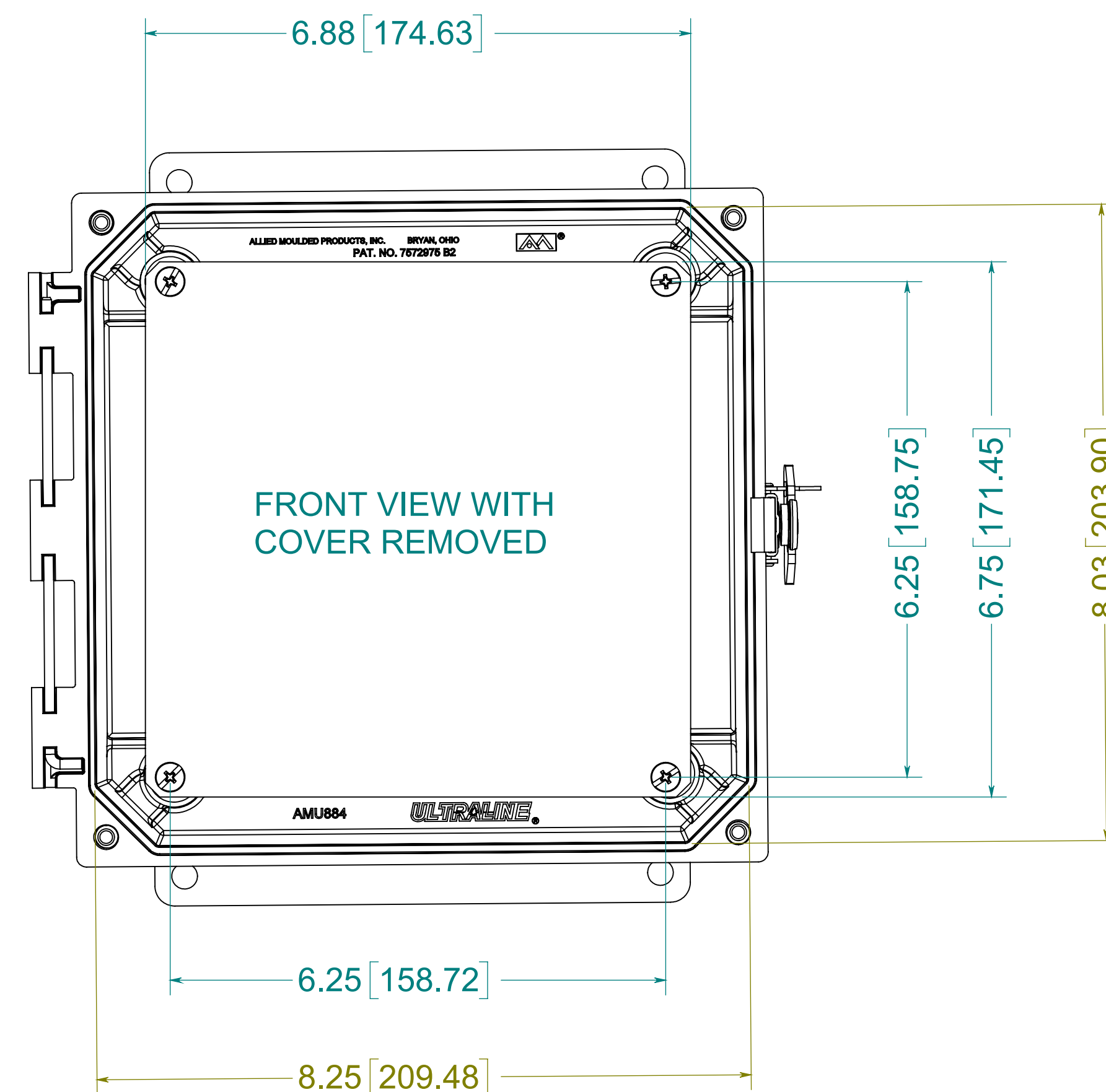
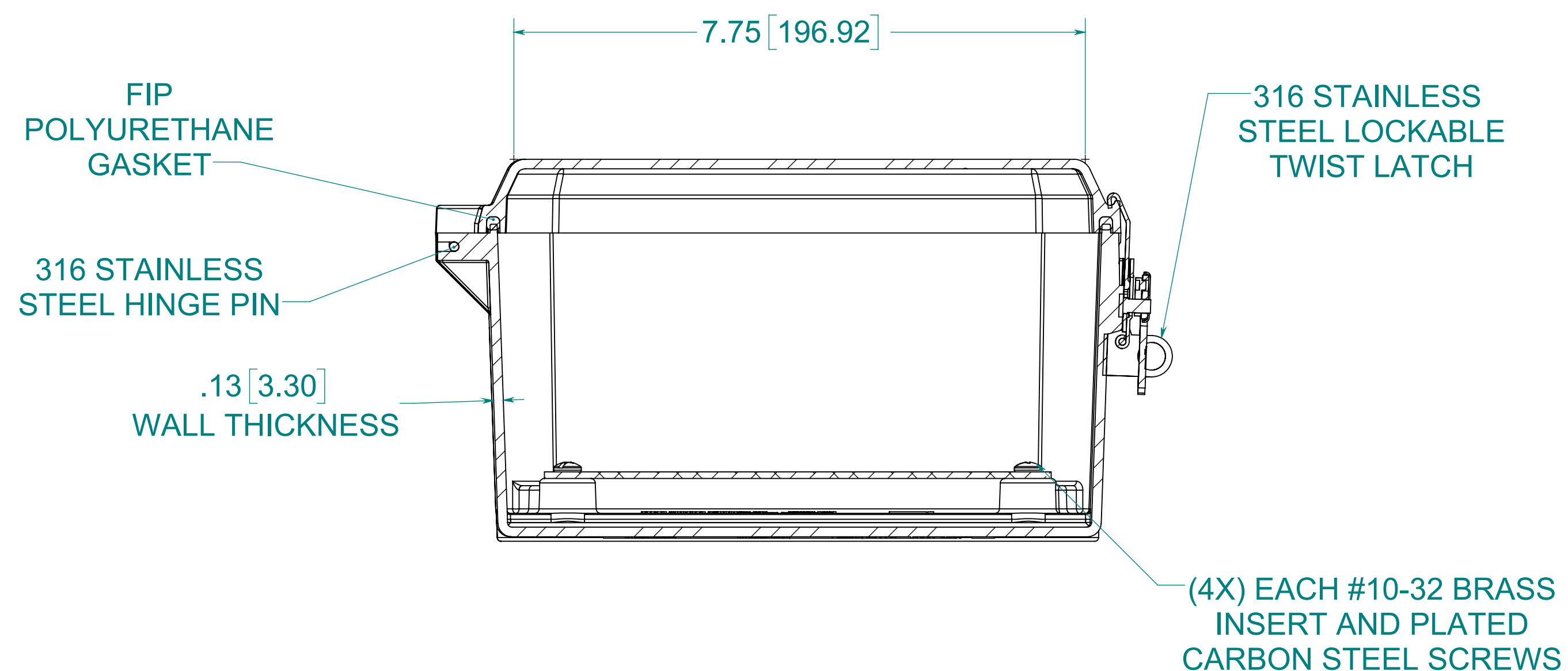
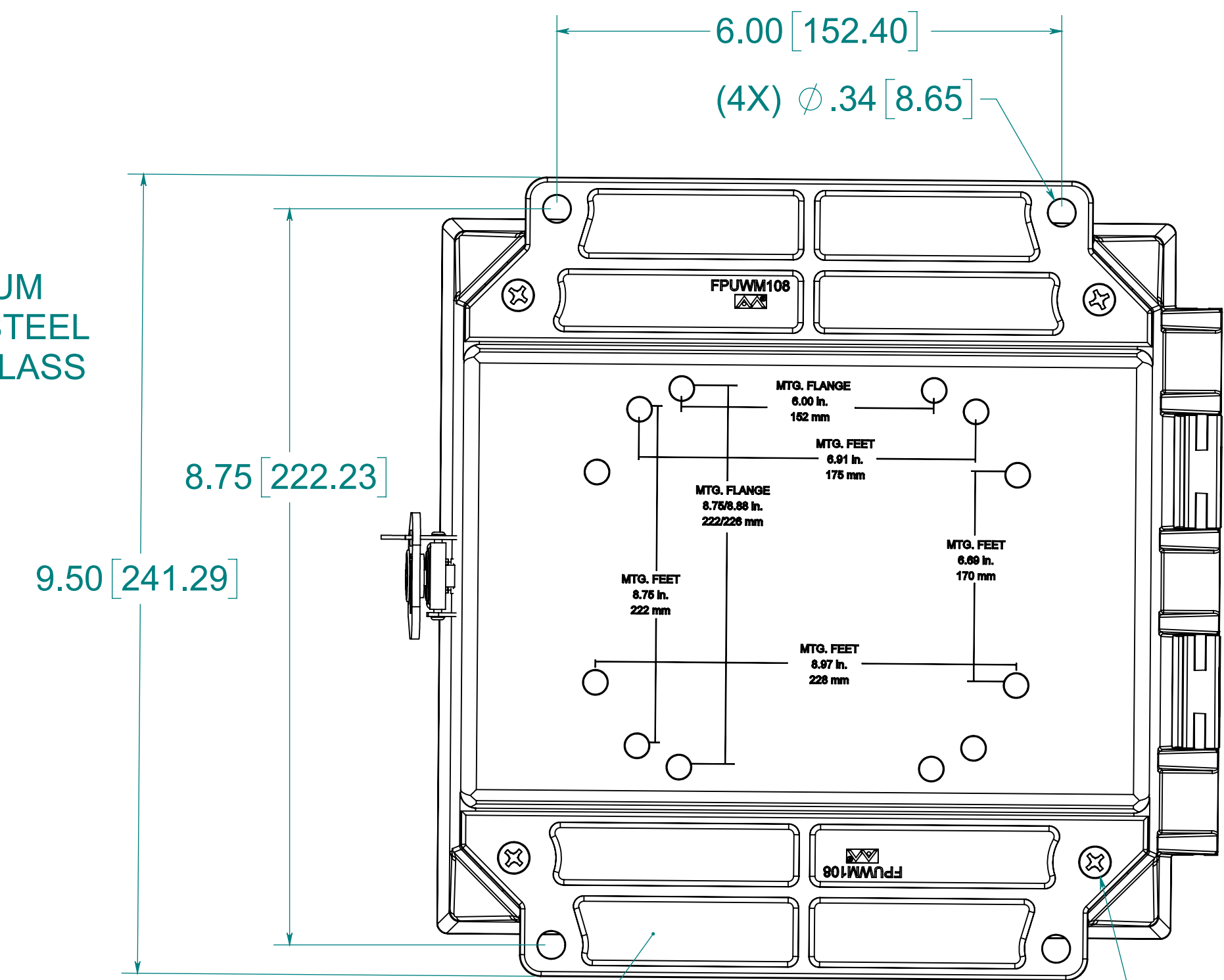
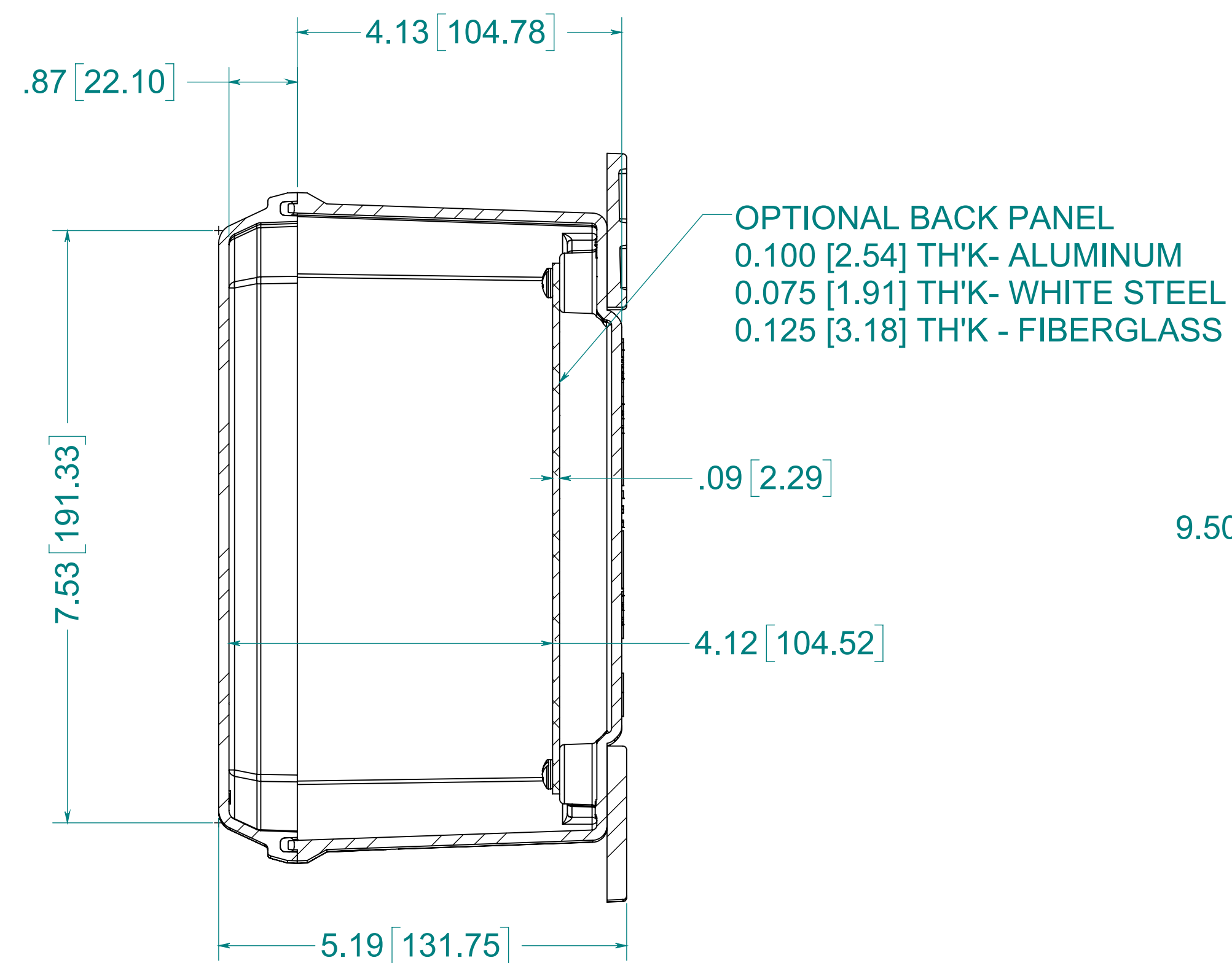
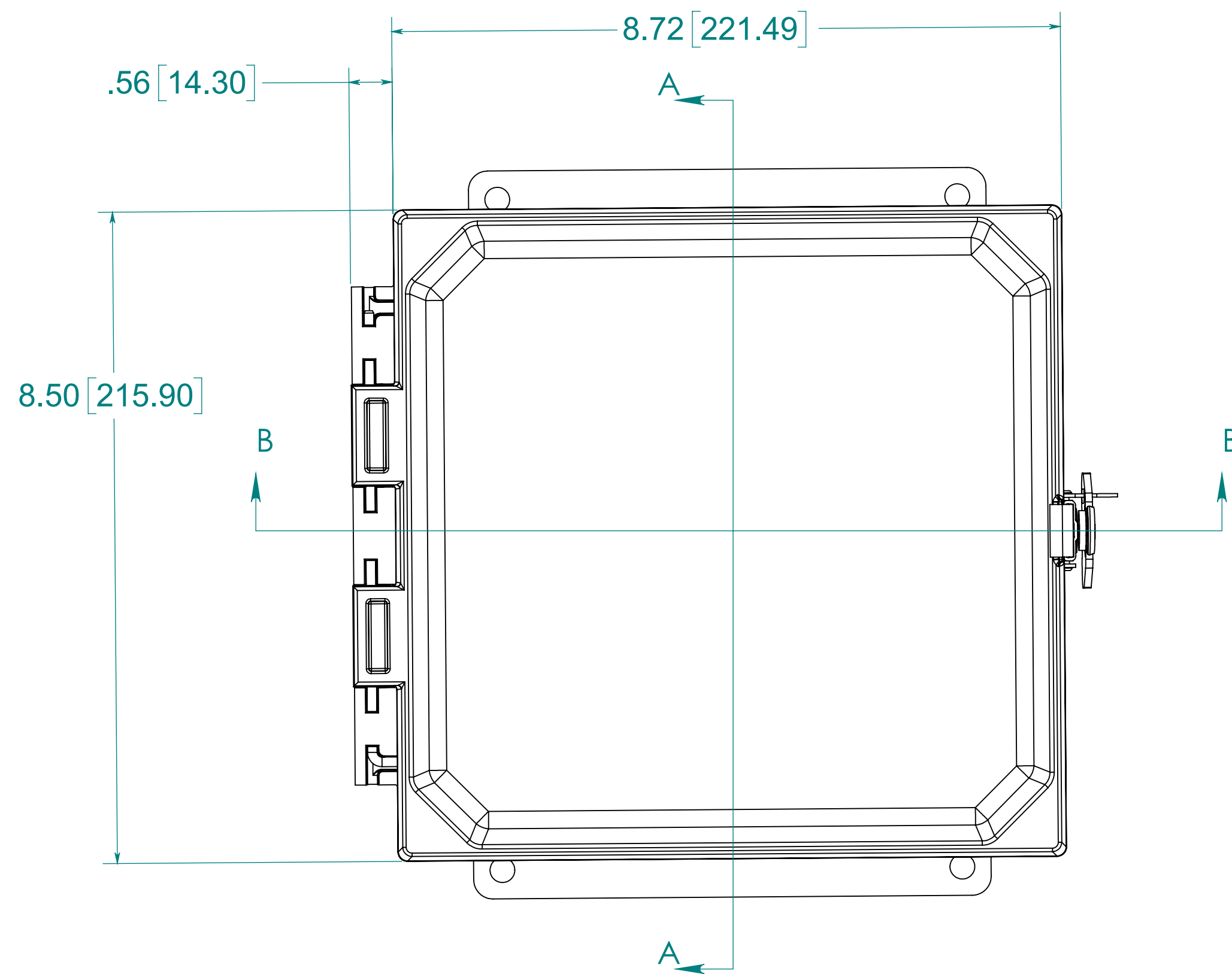

SECTION B-B

MATERIAL:

BOX- COMPRESSION MOLDED FIBERGLASS REINFORCED POLYESTER
 COVER- COMPRESSION MOLDED FIBERGLASS REINFORCED POLYESTER
 CLEAR COVER- INJECTION MOLDED POLYCARBONATE

NOTE:
 1. DATA SUBJECT TO CHANGE WITHOUT NOTICE



THIS MATERIAL IS OWNED BY THE ALLIED MOULDED PRODUCTS COMPANY, IS DISCLOSED IN CONFIDENCE, AND IS NOT TO BE REPRODUCED OR DISTRIBUTED WITHOUT PRIOR WRITTEN PERMISSION FROM ALLIED MOULDED PRODUCTS.
 © 2017 Allied Moulded Products, Inc. All Rights Reserved

AMU Ultraline
 AMU884TF