

flexBOX® Material & Labor Saving Features

Allied Moulded flexBOX switch and outlet boxes are molded of engineering grades of nonmetallic thermoplastic materials. Our flexBOX line of products was created for the electrical contractor looking for nonmetallic outlet boxes with "soft box" characteristics. Allied Moulded's flexBOX line offers the following material advantages:

- Non-corrosive
- Non-conductive
- Lightweight
- No accessory clamps
- Splined thread holes (wall boxes)
- Molded-in splined device holes (ceiling boxes)

Learn more about
flexBOX® products now!

Labor saving features include:

- Patented #6,365,831 B1 integral Speed Klamps™
- Molded thread device holes for wall boxes
 - Optional Quick Thread™ device holes
- Molded-in splined device holes for secure fixture installation
- Proudly UL® listed
- 2-Hour Fire Rated clearly marked for easy inspector identification
- Large cubic inch capacity clearly marked and easy for contractor and inspector to locate and identify
- Stabilizing bracket for maximum support and flush face alignment of wall boxes
- Molded wallboard tabs for securing multi-gang boxes on the opposite end of the framing stud
- Wall box face brackets for steel or wood stud construction
- Offset gauge marks on box give positive stop for the proper wall thickness
- Square corner design for easy wall cut-in
- Steel wing brackets for secure box mounting
- ½" knockouts in multi-gang old work boxes for use with wire/conduit connectors
- Molded flange and steel snap bracket for secure old work box installation
- Round exterior for easy wall cut-in
- Optional ground strap
- Internal holding slots for low voltage partitions (available on specific multi-gang boxes for dual voltage applications)

flexBOX®

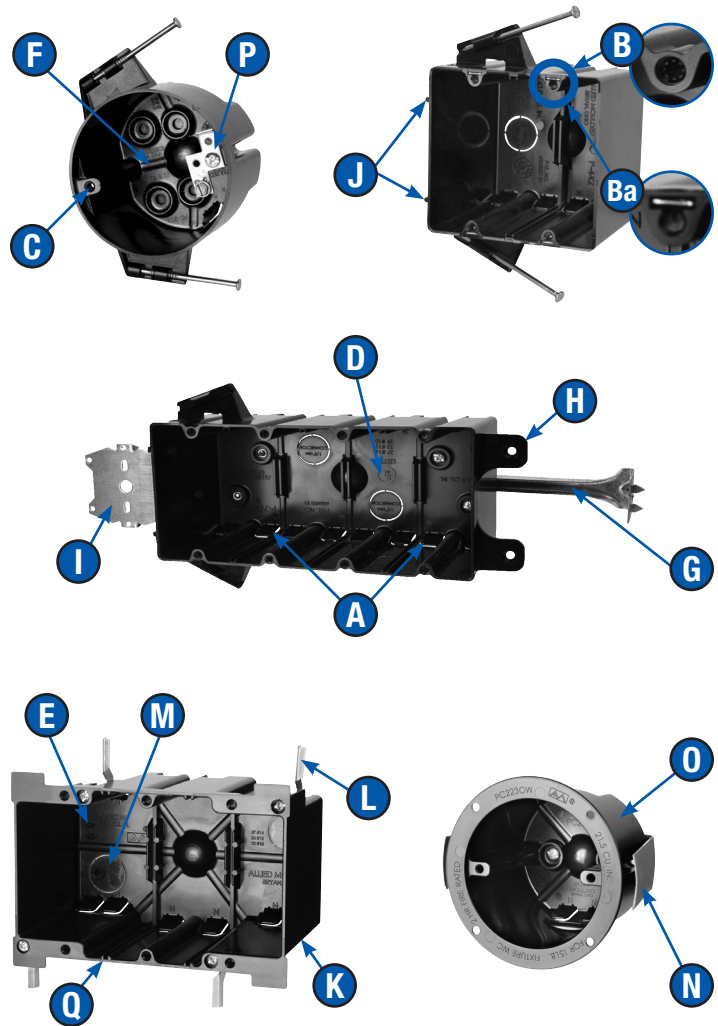
**flexBOX® Attachment Codings**

- | | | | |
|-----------|--|-----------|---|
| B | Stabilizer bracket | N | Nail on mounting |
| G | Ground strap | H | Face bracket for steel and wood stud mounting |
| R | Reverse nail mounting option | QT | Quick Thread™ device hole option |
| BH | Adjustable bar hanger for 16" to 24" joist spacing | 16 | Bar hanger max 16" joist spacing |

All dimensions are in inches unless otherwise noted.

Old Work/Manufactured Housing Boxes

Flush-Device
Box
UL File No. E30594



*Quick Thread™ device hole



Nail-On	Cu. In. Volume	Catalog Number	Component Description	Exterior Dimensions			UPC# 85339	Std. Pkg. Qty.	Std. Wt. (lb.)
				D	W	H			
	18.0	P-181	Single gang, angled mid-nails	2-5/8	2-5/16	3-3/4	24391	100	21
	18.0	P-181QT	Single gang, angled mid-nails, Quick Thread™ device holes	2-5/8	2-5/16	3-3/4	24399	100	21
	18.0	P-181RK	Single gang, reverse nails, molded-in Speed Klamps™	2-11/16	2-5/16	3-3/4	24398	100	21
	20.5	P-201	Single gang, angled nails	3-1/16	2-5/16	3-3/4	24900	100	23
	20.5	P-201QT	Single gang, angled nails, Quick Thread™ device holes	3-1/8	2-5/16	3-3/4	24909	100	25
	20.5	P-201R	Single gang, reverse nails	3-1/16	2-5/16	3-3/4	24901	100	24
	23.5	P-122SC	Patented single gang with side cube, angled mid-nails, four wire knockouts, 2 recessed buttons	1-3/4	2-9/32 (5-1/2 overall)	3-3/4	24914	24	9
	24.0	P-241	Single gang, angled nails	3-9/16	2-5/16	3-3/4	24903	100	26
	24.0	P-241QT	Single gang, angled nails, Quick Thread™ device holes	3-9/16	2-5/16	3-3/4	24904	100	27



Face Bracket Mount	Cu. In. Volume	Catalog Number	Component Description	Exterior Dimensions			UPC# 85339	Std. Pkg. Qty.	Std. Wt. (lb.)
				D	W	H			
	18.0	P-181H	Single gang, face bracket mount, 1/2" NM knockouts	2-3/4	2-5/16	3-3/4	24916	48	10
	18.0	P-181HZ	Single gang, face bracket mount, 1/2" NM knockouts, "Z" hanger	2-3/4	2-5/16	3-3/4	24919	36	11
	24.0	P-241H	Single gang, face bracket mount	3-9/16	2-5/16	3-3/4	24907	50	12
	24.0	P-241HQT	Single gang, face bracket mount, Quick Thread™ device holes	3-9/16	2-5/16	3-3/4	24908	50	12

Miscellaneous	Cu. In. Volume	Catalog Number	Component Description	Exterior Dimensions			UPC# 85339	Std. Pkg. Qty.	Std. Wt. (lb.)
				D	W	H			
	8.0	P-108E	Single gang, ears	1-1/4	2-5/16	3-3/4	24917	24	3
	8.0	P-108H	Single gang, side bracket mount	1-1/4	2-5/16	3-3/4	24918	24	3
	16.0	P-1160W	Single gang, ears, wing brackets, 1/2" NM knockouts	2-5/8	2-5/16	3-11/16	24915	48	10
	18.0	P-1180W	Single gang, ears, wing brackets, molded-in Speed Klamps™, 1/2" NM knockout	3	2-1/4	3-11/16	92714	48	11
	22.5	P-1220W	Single gang, ears, wing brackets, molded-in Speed Klamps™, 1/2" NM knockout	3-3/4	2-5/16	3-3/4	24913	48	14

All dimensions are in inches unless otherwise noted.

See page 32 for flexbox® Attachment Coding suffix descriptions.



Old Work/Manufactured Housing Boxes



Flush-Device Box
UL File No. E30594



P-2400W



P-442



P-442H



P-3520W



P-643

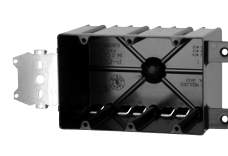

P-643H



*Quick Thread™ device hole

	Cu. In. Volume	Catalog Number	Component Description	Exterior Dimensions			UPC# 85339	Std. Pkg. Qty.	Std. Wt. (lb.)
				D	W	H			
Two Gang	40.0	P-2400W	Two gang, ears, wing brackets, molded-in Speed Klamps™, two ½" knockouts; *Can use LVP-2 partition for dual voltage applications	3-3/8	4-1/8	3-11/16	24912	24	8
	43.0	P-442	Two gang, angled mid-nails, molded-in Speed Klamps™, two ½" knockouts	3-9/16	4	3-¾	44000	50	17
	43.0	P-442QT	Two gang, angled mid-nails, molded-in Speed Klamps™, two ½" knockouts, Quick Thread™ device holes	3-9/16	4	3-¾	44001	50	17
	43.5	P-442H	Two gang, face bracket side mount hanger, molded-in Speed Klamps™	3-9/16	4	3-¾	44002	50	19
	43.5	P-442HQT	Two gang, ace bracket side mount hanger, molded-in Speed Klamps™, Quick Thread™ device holes	3-9/16	4	3-¾	44003	50	21

	Cu. In. Volume	Catalog Number	Component Description	Exterior Dimensions			UPC# 85339	Std. Pkg. Qty.	Std. Wt. (lb.)
				D	W	H			
Three Gang	55.0	P-3520W	Three gang, ears, wing brackets, molded-in Speed Klamps™, two ½" knockouts; *Can use LVP-2 partition for dual voltage applications	3-3/8	5-15/16	3-11/16	33201	12	6
	63.0	P-643	Three gang, angled nails, molded-in Speed Klamps™, two ½" knockouts	3-9/16	5-13/16	3-¾	46302	20	9
	63.0	P-643QT	Three gang, angled nails, molded-in Speed Klamps™, Quick Thread™ device holes, two ½" knockouts	3-9/16	5-13/16	3-¾	46301	20	10
	64.0	P-643H	Three gang, face bracket side mount hanger, molded-in Speed Klamps™	3-9/16	5-13/16	3-¾	46303	20	11
	64.0	P-643HQT	Three gang, face bracket side mount hanger, molded-in Speed Klamps™, Quick Thread™ device holes	3-9/16	5-13/16	3-¾	46304	20	11



P-764



P-764QT



P-764B



P-764H



P-764HB

	Cu. In. Volume	Catalog Number	Component Description	Exterior Dimensions			UPC# 85339	Std. Pkg. Qty.	Std. Wt. (lb.)
				D	W	H			
Four Gang	74.8	P-764	Four gang, angled nails, molded-in Speed Klamps™, two ½" knockouts	3-¼	7-5/8	3-¾	94060	20	11
	74.8	P-764QT*	Four gang, angled nails, molded-in Speed Klamps™, Quick Thread™ device holes, two ½" knockouts	3-¼	7-5/8	3-¾	94063	20	10
	74.8	P-764B*	Four gang, angled nails, molded-in Speed Klamps™, stabilizer bracket, two ½" knockouts	3-¼	7-5/8	3-¾	94061	20	14
	74.8	P-764BQT*	Four gang, angled nails, molded-in Speed Klamps™, stabilizer bracket, Quick Thread™ device holes, two ½" knockouts	3-¼	7-5/8	3-¾	94062	20	15
	74.8	P-764H*	Four gang, face bracket side mount hanger, molded-in Speed Klamps™, two ½" knockouts	3-¼	7-5/8	3-¾	94064	12	9
	74.8	P-764HQT*	Four gang, face bracket side mount hanger, molded-in Speed Klamps™, Quick Thread™ device holes, two ½" knockouts	3-¼	7-5/8	3-¾	94065	12	9
	74.8	P-764HB*	Four gang, face bracket side mount hanger, molded-in Speed Klamps™, stabilizer bracket, two ½" knockouts	3-¼	7-5/8	3-¾	94066	6	5
	74.8	P-764HBQT*	Four gang, face bracket side mount hanger, molded-in Speed Klamps™, stabilizer bracket, Quick Thread™ device holes, two ½" knockouts	3-¼	7-5/8	3-¾	94067	6	6

*NOTE: flexbox four gang switch/receptacle boxes are **not** UL classified for fire resistive walls.

All dimensions are in inches unless otherwise noted.

See page 32 for flexbox® Attachment Coding suffix descriptions.



Old Work/Manufactured Housing Boxes



Flush-Device Box

UL File No. E30594



LVP-2



P2400W with LVP-2 installed

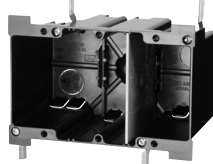

P3520W with LVP-2 installed

Low Voltage Partition	Catalog Number	Component Description	UPC# 85339	Std. Pkg. Qty.	Std. Wt. (lb.)
	LVP-2	Low voltage divider plate for use with the following part numbers: P-442, P-442QT, P-643, P-643QT, P-764, P-764QT, P-764B, P-764H, P-764HBQT, P-2400W, and P-3520W		80005	50*

* Consists of five (5) packages of ten (10) pieces each.



PJ-20N



PJ-20H



PJ-32N



PJ-32H



PJ-4S1



PJ-4T1



PJ-4B

4" Square Junction Boxes	Cu. In. Volume	Catalog Number	Component Description	Exterior Dimensions			UPC# 85339	Std. Pkg. Qty.	Std. Wt. (lb.)
				D	W	H			
20.5	PJ-20N	4" square junction box, angled nails, molded-in Speed Klamps™	1-5/8	4	4	99001	48	11	
20.5	PJ-20H	4" square junction box, face bracket side mount hanger, molded-in Speed Klamps™	1-5/8	4	4	99000	48	15	
32.5	PJ-32N	4" square junction box, angled nails, molded-in Speed Klamps™	2-1/2	4	4	99003	48	13	
32.5	PJ-32H	4" square junction box, face bracket side mount hanger, molded-in Speed Klamps™	2-1/2	4	4	99002	48	17	

Plaster Rings/Cover	Cu. In. Volume	Catalog Number	Component Description	Exterior Dimensions			UPC# 85339	Std. Pkg. Qty.	Std. Wt. (lb.)
				D	W	H			
4.2	PJ-4S1	Single gang plaster ring for use w/ 4" square junction box, 1/2" offset	5/8	4	4	99004	100	8	
5.1	PJ-4S2	Single gang plaster ring for use w/ 4" square junction box, 5/8" offset	3/4	4	4	99005	50	5	
6.7	PJ-4T1	Two gang plaster ring for use w/ 4" square junction box, 1/2" offset	5/8	4	4	99006	50	4	
8.1	PJ-4T2	Two gang plaster ring for use w/ 4" square junction box, 5/8" offset	3/4	4	4	99007	50	4	
—	PJ-4B	Square blank cover for use with 4" square junction box	—	4	4	99008	100	8	

All dimensions are in inches unless otherwise noted.
See page 32 for flexbox® Attachment Coding suffix descriptions.



3-1/2" Dia. Round Outlet	Cu. In. Volume	Catalog Number	Component Description	Exterior Dimensions		Fixture Rating	UPC# 85339	Std. Pkg. Qty.	Std. Wt. (lb.)
				D	W				
	21.0	PC213-N	Angled fetter ring nails, molded-in Speed Klamps™	2-13/16	3-1/2	50 lb.	98011	50	12
	21.0	PC213-NG	Angled fetter ring nails, molded-in Speed Klamps™, ground strap	2-13/16	3-1/2	50 lb.	98012	50	13
	21.5	PC2230WG	Flange, snap bracket, ground strap, molded-in Speed Klamps™	2-13/16	3-1/2	■	98029	24	10
21.5	PC2230W	Flange, snap bracket, molded-in Speed Klamps™	2-13/16	3-1/2	■	98028	24	9	

*3-1/2" Dia. Round Outlet w/ Bar	Cu. In. Volume	Catalog Number	Component Description	Exterior Dimensions		Fixture Rating	UPC# 85339	Std. Pkg. Qty.	Std. Wt. (lb.)
				D	W				
	21.0	PC213-BH**	16" - 24" adjustable bar hanger, molded-in Speed Klamps™	2-13/16	3-1/2	50 lb.	98030	24	27
	21.0	PC213-BHG**	16" - 24" adjustable bar hanger, ground strap, molded-in Speed Klamps™	2-13/16	3-1/2	50 lb.	98031	24	27
	21.0	PC213-16*	16" bar hanger, molded-in Speed Klamps™	2-13/16	3-1/2	50 lb.	98304	24	17
21.0	PC213-16G*	16" bar hanger, ground strap, molded-in Speed Klamps™	2-13/16	3-1/2	50 lb.	98305	24	17	

NOTES: * For maximum 16" on-center joist applications only
 ** For 16" - 24" on-center joist applications
 ■ Meets NEC for wall applications

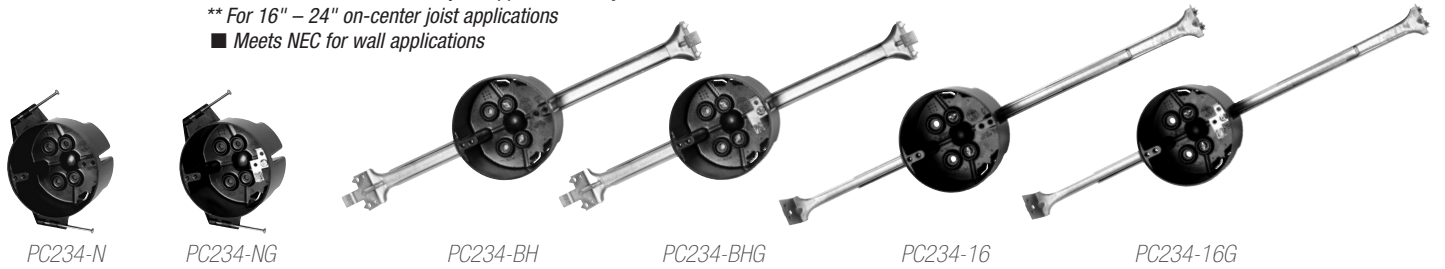

4" Dia. Round Outlet	Cu. In. Volume	Catalog Number	Component Description	Exterior Dimensions		Fixture Rating	UPC# 85339	Std. Pkg. Qty.	Std. Wt. (lb.)
				D	W				
	23.0	PC234-N	Angled fetter ring nails, molded-in Speed Klamps™	2-5/16	4	50 lb.	98025	50	12
23.0	PC234-NG	Angled fetter ring nails, ground strap, molded-in Speed Klamps™	2-5/16	4	50 lb.	98026	50	13	

**4" Dia. Round Outlet w/ Bar	Cu. In. Volume	Catalog Number	Component Description	Exterior Dimensions		Fixture Rating	UPC# 85339	Std. Pkg. Qty.	Std. Wt. (lb.)
				D	W				
	23.0	PC234-BH**	16" - 24" adjustable bar hanger, molded-in Speed Klamps™	2-5/16	4	50 lb.	98032	24	27
	23.0	PC234-BHG**	16" - 24" adjustable bar hanger, ground strap, molded-in Speed Klamps™	2-5/16	4	50 lb.	98033	24	27
	23.0	PC234-16*	16" bar hanger, molded-in Speed Klamps™	2-5/16	4	50 lb.	98306	24	16
23.0	PC234-16G*	16" bar hanger, ground strap, molded-in Speed Klamps™	2-5/16	4	50 lb.	98307	24	16	

NOTES: * For maximum 16" on-center joist applications only; ** For 16" - 24" on-center joist applications

All dimensions are in inches unless otherwise noted.

See page 32 for flexbox® Attachment Coding suffix descriptions.



Old Work/Manufactured Housing Boxes



Outlet Boxes
UL File No. E30594